

# ***AIR QUALITY MEASUREMENT DEVICE USING PROGRAMMABLE QUADCOPTER DRONE TOWARDS SWARM-IOT (INTERNET OF THINGS)***

Deriel Laska Lubna<sup>1</sup>, Nyoman Bogi Aditya<sup>2</sup>, Soo Young Shin<sup>3</sup>

<sup>1</sup>Telecommunication Engineering , School of Electrical Engineering , Telkom University

<sup>1</sup>derriellaska@student.telkomuniversity.ac.id, <sup>2</sup>aditya@telkomuniveristy.ac.id,

<sup>3</sup>wdragon@kumoh.ac.kr

---

## **Abstract**

Air pollution is a condition in which air quality is damaged and contaminated either by harmful or harmless substances to living things. The main problem with the air quality measurement system in the field is the inaccuracy. This is due to the system installation is installed in an area where there is a lot of traffic pollution. This thesis created an alternative method to measure air quality using overground measurements. This thesis invented an Air Quality Measurement Device Using Programmable Quadcopter Drone Towards Swarm-IoT (Internet of Things). With this alternative, Swarm-IoT drone can measure air quality above ground level. This thesis measured air quality using the MQ-135 sensor with a value range of 10 - 10000 ppm. Measurement of temperature and humidity using the DHT22 sensor. The range temperature is  $-40^{\circ}\text{C} + 80^{\circ}\text{C}$ , and the humidity range is from 0-100%. The temperature has an accuracy of  $0.5^{\circ}\text{C}$ , and the humidity, 2%. NodeMCU as a microcontroller. Data obtained from the sensor processed in NodeMCU and the database's data over a Wi-Fi network displayed on Android. With these components, drones can measure air quality at an altitude of 0 m, 3 m and 5 m. The results denoted that the quadcopter can automatically detect air quality. Measurements of the data were viewed directly via a smartphone in real-time. Air quality testing was carried out in two places, namely GSG and Ciganitri field. The tests were done to determine the value of good air quality. The findings showed that good air quality was below the range of 720, and the worst was above 780. The average air quality results at the GSG at an altitude of 0m was 396, at an altitude of 3m was 389, and at an altitude of 5m was 387. While in the Ciganitri field, the average of air quality at an altitude of 0m was 695, at an altitude of 3m was 696, and at an altitude of 5m was 694. The deviation value of temperature measurement using a thermometer as a reference to obtain a value of 1.8 indicated that the measurement results using a sensor test device were close to accurate results.

**Keywords: IoT, Sensors, Drone, Air Quality.**

---

## **1. Introduction**

Cities are multi-system operating environments equipped by sensors aiming to get data of traffic, water distribution networks, electricity networks, and air quality stations [1]. Due to Indonesia's high rate of congestions, the air quality is highly polluted. Air pollution comes from land transportation, industrial emissions, and densely populated residential areas where most of the people carry out their activities. It has a severe impact on public health. An example of a disease caused by air pollution is respiratory tract inflammation. This disease is the sixth leading cause of death in Indonesia after diarrhea, cardiovascular, tuberculosis, and measles. Air pollution is perhaps Indonesia's most severe environmental problem. The current quality measurement system is considered inaccurate as it only measures at a certain point around but provides inaccurate results influenced by various aspects. The measurements in this field are not carried out evenly because there are some inaccessible areas, leaving only a limited range of areas can be measured. Land access is usually obstructed and full of obstacles. It takes an air monitoring robot to allow all areas accessed without any ground barrier. This thesis invented an IoT drone swarm as an overground air quality measuring devices. With this tool, air quality measurements will be more accurate and efficient. By looking at all these problems, this thesis invented an air quality measuring device in the form of a

drone that is able to measure air quality overground. The drone used a sophisticated autopilot system called the Pixhawk. The drone was equipped with DHT-22 and MQ-135 to get precise humidity and air quality data. To run this sensor, the drone uses NodeMcu as a microcontroller equipped with an ESP8266 Wi-Fi module inside. The data from the sensor were sent to NodeMcu for processing. The data that had been processed were stored in a firebase via Wi-Fi network connected to the internet. The measurement data obtained were displayed on the user's device.

## 2. Research Method

### 2.1 Internet of Things

Internet of Things is a global infrastructure for the data society, enabling advanced ad- services by interconnecting (physical and virtual) things based on existing and evolving interoperable information and communication technologies. The internet of things (IoT) perceived as a far-reaching vision with technological and societal implications. From the perspective of technical standardization, the IoT is viewed as a worldwide infrastructure for the data society, enabling advanced services by interconnecting (physical and virtual) things based on existing and evolving interoperable information and communication technologies (ICT). Through the exploitation of identification, data capture, processing, and communication capabilities, the IoT makes full use of "things" to supply services to any or all sorts of applications while ensuring that security and privacy requirements fulfilled. The IoT is expected to integrate significantly leading technologies, like technologies associated with advanced machine-to-machine communication, autonomic networking, data processing and decision-making, security and privacy protection, and cloud computing, with advanced sensing technologies actuation[2] .

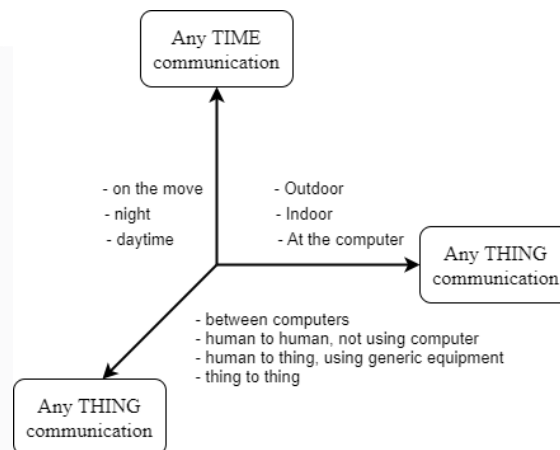

**Fig. 1 – The New Dimension of IoT [b-ITU Report].**

### 2.2 Air Quality Measurement

Air is one of the essential natural elements for living things on earth, especially humans. Air pollution is both an environmental and a social problem, leading to a multitude of adverse effects on human health, ecosystems and the climate [14]. Air pollution includes one of the biggest problems in Indonesia. Related to the congestion of air quality turns out to affect the surrounding community's health, the residual combustion of vehicles contains many CO<sub>2</sub>, where this substance is toxic to humans [14]. Therefore, the government is now measuring and analyzing air parameters to develop air quality monitoring in real-time. The use of a real-time monitoring system allows performing detailed and accurate analysis.

### 2.3 Drone Technology

Drones are tools with advanced technology capable of being controlled and having the ability to fly relatively high and faraway. There are two types of drones, namely Fixed Wing and Multirotor. This type of drone built from a body that has two wings and one propeller. The advantages of this type of drone are good stability, more comprehensive range. Multirotor drone made from a fuselage paired with four motors that move the propellers. The advantages of this type of drone are

agility, manoeuvrability, and precise accuracy. The number of motors distinguishes drone Multirotor itself. In general, this drone has a motor with a number ranging from 3 (Tricopter), 4 (Quadcopter), 6 (Hexa-copter), and 8 (Octocopter). In this thesis, the type of multirotor used is a quad-copter. The quadcopter has four rotors as propeller drives that generate lift. The quadcopter can take off and land vertically. The four motors in the quadcopter can move up, down, forward, backward, left, right, and rotation. The theory for motor movement is called pitch, roll, and yaw.

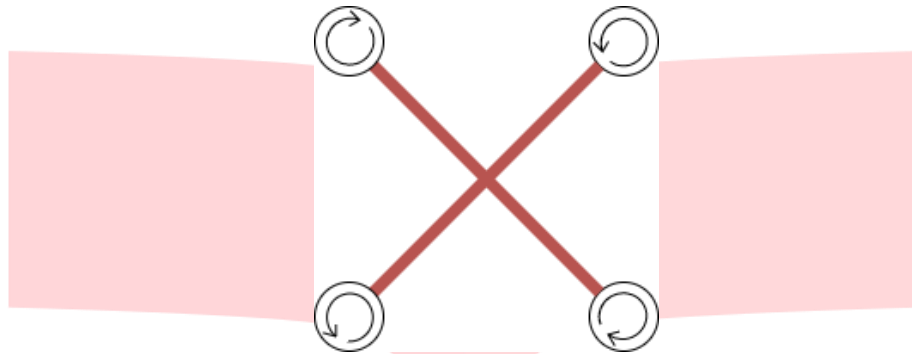

Fig. 2 – Configuration of Rotors.

### 3. System Method

#### 3.1 System Method of Sensor

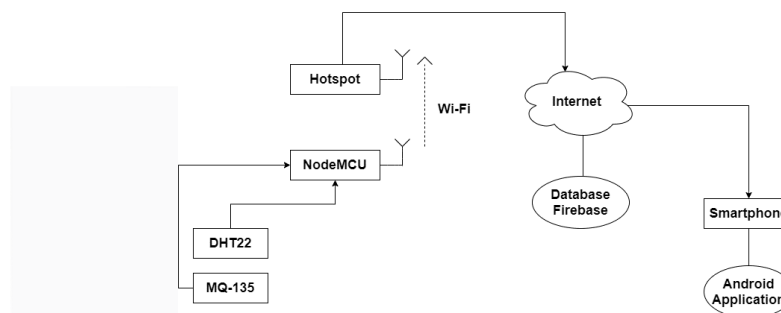

Fig.3 - Overall System Block Diagram.

The dht22 and the MQ-135 used for the sensor subsystems. The IoT Device subsystem used is NodeMcu. For the gateway subsystem, this tool uses the Wi-Fi gateway of the mobile device hotspot network. The IoT Platform / Cloud subsystem used is firebase. The tools in this system consist of DHT22, MQ135, and NodeMCU. In this part of the tool, DHT22 and MQ135 are connected to NodeMcu to transmit the obtained data. In the application section, an application is made on a smartphone as a media for users to display air quality measurements every piece of information obtained by the application stored in the Firebase database. The dht22 and the MQ-135 used for the sensor subsystems. The IoT Device subsystem used is NodeMcu. For the gateway subsystem, this tool uses the Wi-Fi gateway of the mobile device hotspot network. The IoT Platform / Cloud subsystem used is firebase. The tools in this system consist of DHT22, MQ135, and NodeMCU.

#### 3.2 System Method of Connectivity

The purpose of this section is to explain how the connectivity system in this thesis works. In this section, algorithm will be explained.

```
#define WIFI_SSID "Derial"
#define WIFI_PASSWORD ""
```

Fig.4 - Arduino Coding.

Figure 3.6 sets up a wifi connection used so that NodeMcu gets a link to connect to the internet. To define WIFI SSID, fill in the username for the wifi device name, and for WIFI PASSWORD, input the password according to the device used. In that way, NodeMcu will automatically connect to the internet network.

### 3.3 System Method of Platforms

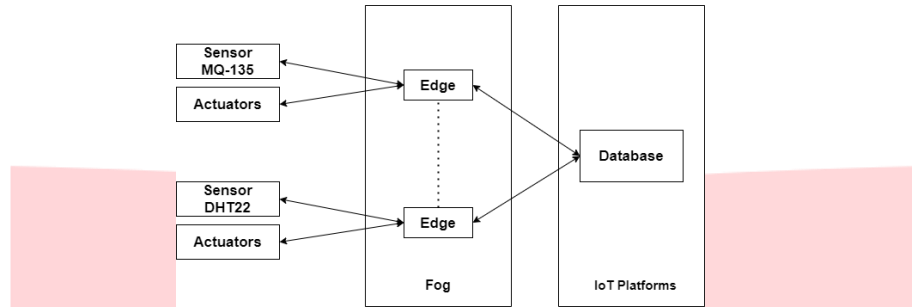

**Fig.5 - Block Diagram of Platform.**

As we can see in the picture 3.6, according to the program made on the Arduino IDE, the MQ-135 sensor and DHT22 sensor will take as much data as possible for 60 seconds. The data obtained by the two sensors and stored in NodeMcu. The fog chart above consists of a device manager, Edge Analytics, and ingest data. The data from the sensors are sent to the database using a Wi-Fi network. The IoT platform used is Firebase. The data received by Firebase connected automatically, and we can see it in real-time on the smartphone screen display.

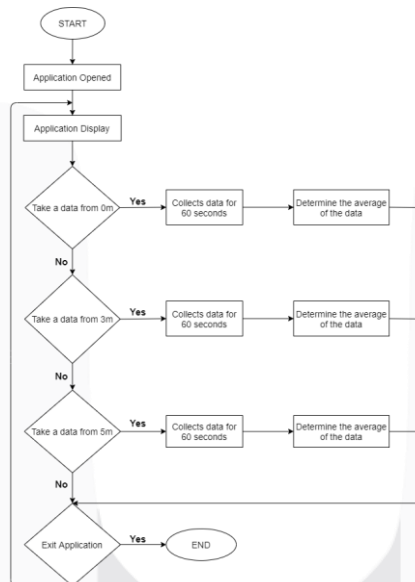

### 3.4 System Method of Application

**Fig.6 - Flowchart of Application.**

Figure 6 is a flowchart of the application section that describes the workflow of applications on smartphones. When the application is opened, the application will display real-time measurement data. The application adds a "Take" button to retrieve data at a predefined height.

- When pressing the take button at an altitude of 0 m, 3 m, and 5 m NodeMcu will retrieve the overall data for 60 seconds. It is sent to firebase to get the average result of the captured data and then display it in the application. After completing all data collection, the application will display the measurement results of each height. Then the application can be closed.

### 3.5 System Method of Drone

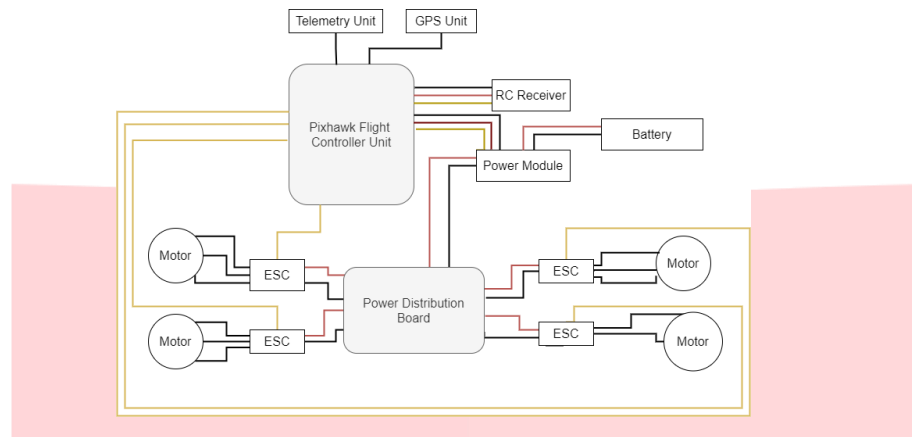

**Fig. 7 - System Block Diagram of Drone.**

The system that realized in this section is a drone. Drones designed to fly and float at a certain altitude, the sensors can take measurements at an altitude of 0m, 3m, and 5m. The type of drone used is a quadcopter that uses the model (X) with dimensions of 450mm. The system consists of hardware, namely f450 frame, brush-less motor, Electric speed control (ESC) 40 Ampere, Pixhawk Flight Controller, 9x4.5 propeller, 5200mAh / 15V Li-Po battery, Telemetry, Gps Module, Power Module, and Receiver.

### 3.6 Testing Scenarios

#### 1. Functional

Drone stability testing aims to see whether the drone's work is stable or not while flying on a mission. The stability of the drone is seen from the graph recorded in the tlog mission planner. The X-axis shows the time, while the Y-axis shows the coordinates of the drone body's slope. The drone is stable when the pitch, roll, and yaw lines are around 0.

#### 2. Reliability and Validity

This test aims to compare the measurement results with tools that have shared values with the sensor made. The MQ-135 sensor measures air quality without using a reference instrument with using alcohol and gas to get a reference value. The DHT22 sensor measures humidity and temperature using a digital thermometer as a reference tool. Air quality measurements carried out at an altitude of 0m, 3m, and 5m. Measurements are made more efficient because measurement results are sent directly to the smartphone so that users can see the results in real-time in the application created.

#### 3. Quality of Service

The parameters to be tested in this thesis are delay and throughput. Measurement of Delay Data was done to measure data transmission speed sent from NodeMcu to Smartphone. Delay measurement is done using a stopwatch on a smartphone. Data sending time calculated from data 1 to data 2 and so on. The throughput calculation is done by dividing the amount of data sent by the time of data transmission. In this throughput measurement, there is only the Uplink value from NodeMcu to the Internet. By testing the parameters above, it can prove whether the air quality measuring instrument using this drone swarm will produce an accurate and efficient value or not. Accuracy and precision show our level of confidence in the measurement results obtained. Accuracy means that our measurement results follow the standard, which means comparing with other standardized measuring instruments. Precision means that our measurement results are conical to a certain number.

#### 4. Testing Result

##### 4.1 Making a prototype of IoT control sub-system

The following is an indicator of the achievement of the control sub-system prototype results:

No	Indicator	Test Result
1	MQ-135 sensor able to measure air quality	Working
2	DHT22 sensor able to measure humidity and temperature	Working
3	NodeMcu able to send data to Firebase	Working
4	All propeller able to rotate	Working
Percentage of Yield		100%

**Table 1.** Indicator of the Achievements Sub-system IoT Control.

### 4.2 Functional Testing Result

This test carried out to test the drone balance's stability, which seen from the drone's roll, pitch, and yaw angle. This drone uses Radio Telemetry as a signal amplifier so that the flight data carried out recorded by Log telemetry or often called "log". This log is recorded by the local PC's mission planner when the autopilot connected via a telemetry link.



**Fig. 8 - Graph of Stability drone in Mission Planner**

The red axis is the pitch value, the green axis is the roll value, and the blue axis is the roll value. This test's angular stability is still in good condition wherein the position's initial minutes are still at point 0. When the drone rises to a higher altitude, the stability begins to be disturbed. The drone isolated between 0m - 3m at which time the ping is read. Likewise, when the drone rises to an altitude of 5m. The overall result of this graph is said to be stable because there are no significant disturbances.

### 4.3 Reliability and Validity Measurement

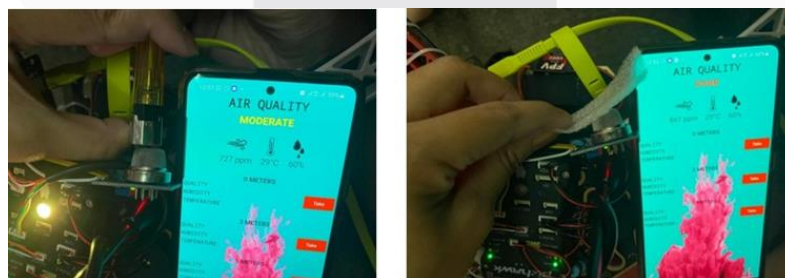

**Fig. 9 - Providing samples for reference data.**

The sampling test found that the reference value for good air quality was below 720 ppm, while from the value of 720ppm-780ppm, the value of air quality was moderate and above 780 was

dangerous.

#### 4.3.1 Quality Measurement

Tests carried out in two places with different air quality, namely the GSG Field and the Ciganitri Field. The GSG field condition is planted with lots of trees; it used to take good air quality. The Ciganitri Field location is close to the construction area and close to a highway

Quality												
	9:00			12:00			16:00			21:00		
Test	0m	3m	5m	0m	3m	5m	0m	3m	5m	0m	3m	5m
1	308	293	286	457	440	438	498	491	488	360	357	356
2	311	294	288	430	429	429	481	480	477	371	360	362
3	306	291	285	392	401	397	489	491	488	347	341	341
4	315	300	305	415	410	407	501	498	491	351	347	348
5	314	298	299	422	419	408	496	496	493	365	361	360

**Table 2** Testing Place : GSG.

Quality												
	9:00			12:00			16:00			21:00		
Test	0m	3m	5m	0m	3m	5m	0m	3m	5m	0m	3m	5m
1	640	634	634	721	725	724	735	734	729	656	650	644
2	637	632	633	724	724	720	715	720	718	677	671	671
3	676	680	678	752	759	758	734	740	739	642	643	642
4	653	661	661	733	733	729	756	761	758	653	656	651
5	620	620	618	749	747	742	777	783	781	655	651	650

**Table 3** Testing Place : Ciganitri Field

Show the results of air quality measurements using the MQ- 135 sensor. The sensor can work well, which is proven by reading the level of pollution in two different places. It can see a significant difference between the two. The measurement results in the Ciganitri Field were higher pollution than those in the Gsg Field. Unlike the Gsg result, which was lower and entered the "Good" index because the number is below 720.

#### 4.3.2 Humidity Measurement

Humidity												
	9:00			12:00			16:00			21:00		
Test	0m	3m	5m	0m	3m	5m	0m	3m	5m	0m	3m	5m
1	65	65	65	64	64	64	64	64	64	65	65	65
2	66	66	66	65	65	65	63	63	63	66	66	66
3	65	65	65	63	63	63	64	64	64	66	66	66
4	68	68	68	59	59	59	65	65	65	67	67	67
5	67	67	67	55	55	55	70	70	70	66	66	66
Average	66	66	66	61	61	61	65	65	65	66	66	66

**Table 4** Testing Place : GSG

Humidity												
Test	9:00			12:00			16:00			21:00		
	0m	3m	5m	0m	3m	5m	0m	3m	5m	0m	3m	5m
1	67	67	67	57	57	57	66	66	66	67	67	67
2	67	67	67	62	62	62	66	66	66	72	72	72
3	65	65	65	63	63	63	63	63	63	64	64	64
4	65	65	65	64	64	64	63	63	63	66	66	66
5	66	66	66	64	64	64	64	64	64	65	65	65
Average	66	66	66	62	62	62	64	64	64	67	67	67

**Table 5** Result in Ciganitri Field

The experimental results measured air humidity at three altitude points, namely 0m, 3m, and 5m. Data were collected using a test tool in the form of a DHT22 sensor. Data collection was carried out for 5 minutes starting at 9 am, and it was repeated three times at 12 pm, 4 pm, and 9 pm. The data obtained in percentage units. Based on the table above, the data from the humidity measurement results tend to be constant. Based on the test results, the DHT22 sensor above shows promising results, as evidenced by the results following the test site's conditions.

#### 4.3.3 Temperature Measurement

Temperature												
Test	9:00			12:00			16:00			21:00		
	0m	3m	5m	0m	3m	5m	0m	3m	5m	0m	3m	5m
1	22	22	22	26	26	26	25	25	25	22	22	22
2	24	24	24	27	27	27	25	25	25	22	22	22
3	24	24	24	26	26	26	24	24	24	21	21	21
4	25	25	25	25	25	25	24	24	24	22	22	22
5	23	23	23	26	26	26	25	25	25	22	22	22
Average	23.6	23.6	23.6	26	26	26	24.6	24.6	24.6	21.8	21.8	21.8

**Table 6** Result in GSG

Temperature												
Test	9:00			12:00			16:00			21:00		
	0m	3m	5m	0m	3m	5m	0m	3m	5m	0m	3m	5m
1	23	23	23	24	24	24	24	24	24	22	22	22
2	23	23	23	26	26	26	25	25	25	24	24	24
3	25	25	25	28	28	28	26	26	26	24	24	24
4	25	25	25	26	26	26	25	25	25	22	22	22
5	23	23	23	27	27	27	25	25	25	23	23	23
Average	23.8	23.8	23.8	26.2	26.2	26.2	25	25	25	23	23	23

**Table 7** Result in Ciganitri Field

Data were collected simultaneously with two measuring instruments: a thermometer and a DHT22 temperature sensor test device. The data presented is the real-time measurement result. The two places' measurement results show a constant temperature value because data collection carried out during the rainy season. However, the temperature measurement results in the Ciganitri Field are higher than in the Gsg Field. The measurement results using a thermometer, and the measurement results using the sensor are not much different. The data obtained is processed to find the deviation value in these measurements. The following is the result of the deviation calculation:

Deviation				
Test	9:00	12:00	16:00	21:00
1	0	1	1	1
2	0	1.5	1	1.5
3	0.5	1	0	2.5
4	0	0	0.5	2
5	0.5	1.5	1	2
Average	0.2	1	0.7	1.8

**Table 8** Deviation of Temperature



Deviation calculation aims to measure the deviation from a measurement result. The smaller the deviation value, the more accurate the value will be. Conversely, the greater the deviation, the less accurate the value will be. The temperature measurement value using a thermometer and sensor has a deviation of 1.8. Shows that the sensors in the system can work optimally.

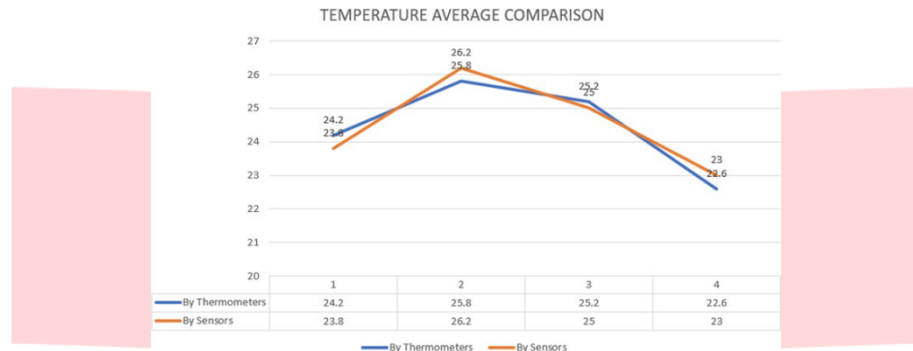

Fig. 10 - Comparison Graph of Temperature Measurement.

The graph above shows that the average value of temperature measurements using a thermometer and sensor has a small comparison value. This supported by the display in the graph that presented. It can see the two lines are close to each other. So that the measurement results are close to accurate.

#### 4.3.4 Quality of Services

##### - Delay

Delay Category	Delay Value	Index
Very Good	less than 150 ms	4
Good	150 - 300	3
Moderate	300 - 450	2
Bad	more than 450	1

Table 9 Delay Standardization (TIPHON)

Test	Time Result (ms)			
	9:00	12:00	16:00	21:00
1	0.2	0.3	0.1	0.1
2	0.2	0.2	0.4	0.1
3	0.1	0.3	0.2	0.2
4	0.2	0.5	0.3	0.2
5	0.1	0.2	0.2	0.2
Overall Average				0.24

Table 9 Result of Data Delay.

The result of the total average delay in the table 9 is 240 ms. When compared with the standardization TIPHON [19] is in the "good" category.

- **Throughput**

Throughput Category	Throughput	Index
Very Good	100%	4
Good	75%	3
Moderate	50%	2
Bad	25%	1

**Table 10** Throughput Standardization (TIPHON).

Throughput(bps)	
Test	Uplink
1	0.88
2	0.92
3	0.88

**Table 11** Result of Throughput

The total average throughput results in the table 11. When compared with the standardization of TIPHON [19], it is in the "Good" category because the total average throughput gets a percentage of 89%.

## 5. Conclusion

From the results of air quality measurements carried out with test equipment in the form of sensors using the IoT Device drone swarm, the following conclusions obtained:

1. Drones have been made that can measure air quality at an altitude of 0m, 3m, and 5m using sensors as an alternative to air quality measurements that send measurement results directly to the user to be more efficient.
2. The measurements results can be seen in real-time via a smartphone application using a Hotspot or Wi-Fi connection. For air quality measurement using MQ-135, the higher the value obtained during measurement, the worse the air quality. The results of measuring air humidity using DHT22, the higher the percentage obtained, the higher the humidity in the measured area. Temperature measurement using DHT22 at an altitude of 0m, 3m, 5m, the results are constant. These measurement results compared with a thermometer measuring instrument, which produces an accurate value because the deviation obtained is 1.8.
3. Measurements can be done anywhere and anytime, as evidenced by measurements made in two different places without having to have a reference time and without carrying other tools. Turn on the drone to fly and take measurements.

## BLIBIOGRAPHY ;

- [1] Renwick, Jason D and Klein, Levente J and Hamann, Hendrik F, Drone-based reconstruction for 3D geospatial data processing. IEEE, 2016.
- [2] ITU-T Y.2060, SERIES Y: GLOBAL INFORMATION INFRASTRUCTURE, INTERNET PROTOCOL ASPECTS AND NEXT-GENERATION NETWORKS. ITU-T, 2021.
- [3] Nashiruddin, Muhammad Imam, INTERNET OF THINGS [IoT]: TECHNOLOGY AND BUSINESS OPPORTUNITIES. IoT Center, 2021.
- [4] Cheng, Wan-Li and Chen, Yu-Song and Zhang, Junfeng and Lyons, TJ and Pai, Joy-Lynn and Chang, Shiang-Hung, Comparison of the revised air quality index with the PSI and AQI indices. IEEE, 2007.
- [5] Haas, Patrick Y and Balistreri, Christophe and Pontelandolfo, Piero and Triscone, Gilles and Pekoz, Hasret and Pignatiello, Antonio, Development of an unmanned aerial vehicle UAV for air quality measurement in urban areas. IEEE, 2014.
- [6] Seiber, Carl and Nowlin, David and Landowski, Bob and Tolentino, Matthew E, Tracking hazardous aerial plumes using IoT-enabled drone swarms. IEEE, 2018.

- [7] Kaleem, Zeeshan and Rehmani, Mubashir Husain and Ahmed, Ejaz and Jamalipour, Abbas and Rodrigues, Joel JPC and Moustafa, Hassna and Guibene, Wael, Amateur drone surveillance: applications, architectures, enabling technologies, and public safety issue. IEEE, 2018.
- [8] Wivou, Josefa and Udawatta, Lanka and Alshehhi, Ali and Alzaabi, Ebrahim and Albeloshi, Ahmed and Alfalasi, Saeed, Air quality monitoring for sustainable systems via drone based technology. IEEE, 2016.
- [9] Guillen-Perez, Antonio and Sanchez-Iborra, Ramon and Cano, Maria-Dolores and Sanchez-Aarnoutse, Juan Carlos and Garcia-Haro, Joan, WiFi networks on drones. IEEE, 2016.
- [10] H. P. Breivold and K. Sandström, Internet of Things for Industrial Automation Challenges and Technical Solutions. IEEE, 2015.
- [11] P. V. Dudhe and N. V. Kadam and R. M. Hushangabade and M. S. Deshmukh, Internet of Things (IOT): An overview and its applications. IEEE, 2017.
- [12] Harmon, Robert R and Castro-Leon, Enrique G and Bhide, Sandhiprakash, Smart cities and the Internet of Things. IEEE, 2015.
- [13] Arasteh, H and Hosseinneshad, V and Loia, V and Tommasetti, A and Troisi, O and Shafie-Khah, M and Siano, P, Iot-based smart cities: a survey. IEEE, 2016.
- [14] Marinov, Marin B and Topalov, Ivan and Gieva, Elitsa and Nikolov, Georgi, Air quality monitoring in urban environments. IEEE, 2016.
- [15] Saputra, Laurentius Kuncoro Probo and Lukito, Yuan, Implementation of air conditioning control system using REST protocol based on NodeMCU ESP8266. IEEE, 2017.
- [16] Abdulrazzak, L and Bierk, IA and Aday, H, Humidity and temperature monitoring. 51745177, 2018.
- [17] Moroney, Laurence, The firebase realtime database. Springer, 2017.
- [18] Vijayalakshmi, VJ and others, Centralized Attendance Monitoring System. IEEE, 2020.
- [19] TR 101 329 V2.1.1, Telecommunications and Internet Protocol Harmonization Over Networks (TIPHON); General aspects of Quality of Service (QoS). ETSI, 1999.
- [20] N. Karna, I. Supriana and N. Maulidevi, "Autonomous knowledge-based system for sensor network," 2015 3rd International Conference on Information and Communication Technology (ICoICT), Nusa Dua, 2015, pp. 92-96, doi: 10.1109/ICoICT.2015.7231403.