

Design And Auto Feeder Catfish Cultivation Based On Internet Of Things

1st M. Abdur Rohman Wachid
Faculty of Information Technology and
Business
Institut Teknologi Telkom Surabaya
Surabaya, Indonesia
mabdur@student.itelkom-sby.ac.id

2nd Dr. Helmy Widyantara, S.Kom., M.Eng.
Faculty of Information Technology and
Business
Institut Teknologi Telkom Surabaya Surabaya,
Indonesia
helmywid@ittelkom-sby.ac.id

3rd Khodijah Amiroh, S.ST., M.T.
Faculty of Information Technology and
Business
Institut Teknologi Telkom Surabaya
Surabaya, Indonesia
dijaamirah@ittelkom-sby.ac.id

Abstract— Catfish farming, cultivators must provide catfish feed regularly. Giving adult catfish, the frequency is 4-6 times a day. Because many cultivators from the group had limited time. As a result, the process of feeding catfish tends to be irregular and sometimes the dosage of feeding catfish is disturbed by its growth and dies. Based on the problems experienced by cultivators, a solution emerged by applying automatic feed technology. This technology provides fish feed automatically based on the time and weight of the feed that has been determined, in real-time using West Indonesian Time. The test results on the automatic feed system using the Close loop control system method were obtained in the first experiment, catfish increased its initial biomass of 4,070 grams and obtained an average weight of catfish of 50.9 grams until the tenth age of 7,410 grams with an average weight catfish 92 grams. After that, 50 catfish were re-sorted as samples for the second study. Based on the results of catfish biomass calculations, the eleventh day biomass was 4,665 grams and the average weight of catfish was 90.3 grams. Fish biomass on the twentieth day gained a weight of 5,900 grams with an average weight of 128 grams with the death of 4 catfish. The ideal water conditions for catfish are pH levels between 6-8, and temperatures of 26-29°C.

Keywords: automatic feed, catfish, fish feed, pH, water temperature. **Introduction**

I. INTRODUCTION

In catfish farming activities there are several things that must be considered, especially catfish feeding [1]. Feeding catfish is one of the most important parts in terms of maintaining and even cultivating catfish, for farmers it can reduce anxiety about the condition of the catfish. This fish, which does not have scales, has a carnivorous eating habit and tends to be omnivorous. Catfish also have nocturnal eating behavior, which is a predatory fish at night [2]. Therefore, making a schedule for feeding catfish for 24 hours will be regulated by an automatic feeder that is scheduled to eat catfish according to a predetermined time, measuring catfish food seen from the weight of the food based on grams and the quality of the food to be given. Optimization of the growth and development of catfish is very necessary, fisheries experts have provided minimum criteria or standards for pond water quality both chemically and physically that must be met for catfish farming [4]. The ideal temperature for catfish farming is a stable temperature in the range of 25°C to 30°C. The environmental pH value factor also greatly influences the growth of catfish, so it is necessary to monitor the pH value periodically. The ideal pH value for catfish farming is around 6.5 – 8. The amount of water temperature will be directly proportional to the increase in water pH and inversely proportional to the oxygen content in the water [5].

Therefore, this automatic feed is useful for feeding catfish regularly and can provide quality food for catfish hatcheries [6]. Automatic feed solutions work in real-time to prevent catfish cannibalism from occurring, and maintain catfish nutrition by relying on a series of microcontroller devices that can minimize time for people who have work routines with fairly tight working hours [3].

II. METHODS

A. Research Procedures

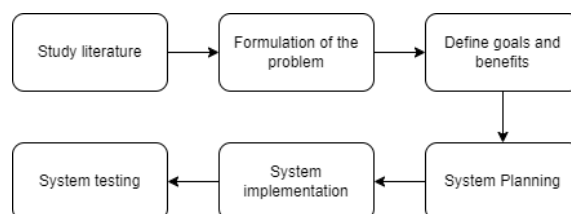

Figure 1 Research Procedure

This research procedure was made to serve as a reference in carrying out the steps, procedures, and flow stages in conducting research conducted by researchers.

B. System Block Diagram

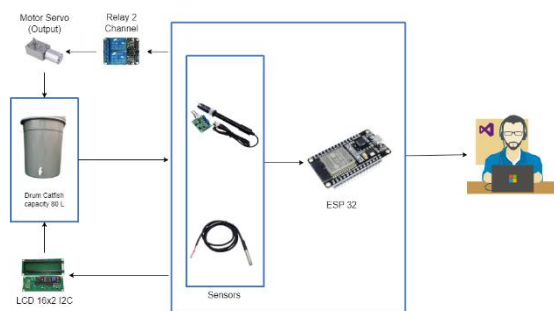

Figure 2 System Block Diagram

how to design systems so that they are interconnected and communicate with one another. The power supply as a supplier of electric power for the ESP32 microcontroller functions to drive the servo motor and is used for Automatic Feed control. Automatic Feeding is also equipped with a water pH sensor which functions to monitor the condition of pond water, if the water pH is bad, it means that the water must be replaced and is equipped with a DS18B20 temperature sensor to maintain the water temperature in the pond.

C. System Flowchart

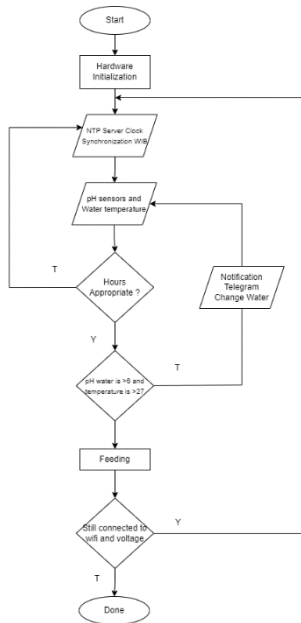

Figure 3 System Flowchart

how do the devices used for monitoring the design of automatic catfish feed work. Starting from hardware initialization, with the addition of a telegram which functions as a tool for monitoring and displaying an information system about the condition of the water in an 80 L bucket.

D. Hardware Design

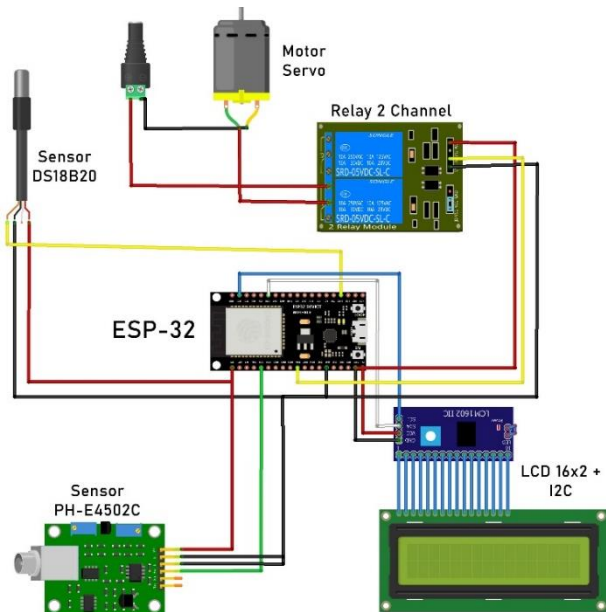

Figure 5 Hardware Design

The process of making hardware designs, each hardware device will be connected to each other using jumper cables connected to the breadboard. The function of the breadboard is to connect several sensors to the microcontroller, because the microcontroller cannot connect all the sensors that will be used directly through this jumper cable. It can be seen that the port connected between the microcontroller and micro USB. In the connection section, there are various ways to communicate between the ESP-32 microcontroller and micro

USB. On ESP-32, data will be sent using IO 34, IO 26, and IO 15. If everything has been connected and connected, later on the ESP-32 microcontroller will be connected to a micro usb charger to get supply from the mains voltage.

III. RESULT AND DISCUSSION

A. Hardware Implementation

Hardware design is a stage by combining all hardware components so that they are connected and communicate with each other via serial or wireless. The following are the main hardware components that will later be interconnected with electric current, as shown in Figure 4.1. Hardware components that have been designed and put together with the aim of implementing IoT system testing. Figure 5 shows the automatic feed conditions used for testing, with the hardware located in the black box in the form of an ESP-32 microcontroller, a JGY370 DC Servo Motor which functions to drop feed from its place, 2 channel relay as a voltage regulator switch between microcontrollers, sensors water temperature, pH sensor- E4502C

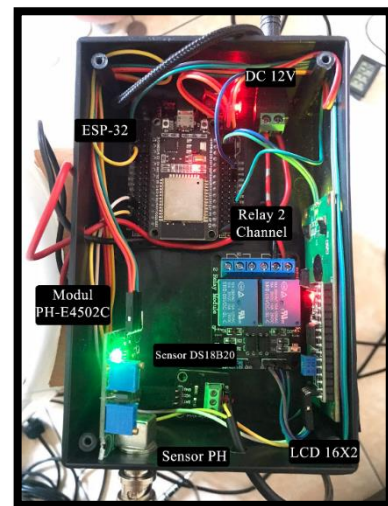

Figure 6 Hardware



Figure 4 Automatic feed over 80 L bucket

B. Software Design

Software design uses the Telegram BOT application where users can send several commands:

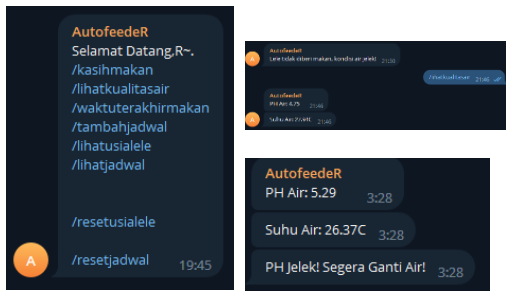

Figure 7 Display on Telegram

1. Feeding: Manual feeding option for 5 seconds if the catfish is still active.
2. Look at the water quality: To see the quality of the water with the condition of the water pH and water temperature being stable, if the pH number shows below 6 and the water temperature is below 26 then a notification will appear "Change Water Immediately"
3. Last feeding time : to see when last feeding.
4. Add schedule: to add 2x schedule, from 4x to 6x.
5. Look at the age of the catfish: to display the age of the catfish
6. View schedule: to view the 4x or 6x automatic feed schedule.
7. Reset catfish age: to reset the age if the harvest is finished and the age starts at 0 again
8. Reset schedule: to reset the schedule, return to the automatic 4x feed schedule

C. Data collection

In the first phase of the trial from 1-10 July 2023 in table 4.10, feeding 4x a day the system works according to predetermined conditions with a pH > 6 and temperature > 26 if pH < 6 and temperature < 26 then the fish are not fed and there is a notification to change the water immediately. The second phase of the trial is July 11-20 2023 in table 4.11 feeding 6x a day. In the second phase of the trial the system worked according to predetermined conditions with a pH > 6 and a temperature > 26 if a pH < 6 and a temperature < 26 then the fish were not fed and there was a notification to change the water immediately.

Table 1 Feeding 4x

Age	Date	Before feeding		After feeding		Automatic feed schedule			
		Water pH	Water temperature	pH quality of water	Quality Water temperature	Giving 7.30	Giving 12.30	Giving 17.01	Giving 21.30
1	7-1-2023	7.65	27.31C	7.6	27.31C	okay			
		7.46	28.75C	7.14	28.87C		okay		
		7.06	30.19C	7.51	30.12C			okay	
		6.53	29.81	6.43	28.62C				okay
2	7-2-2023	5.6	28.56C	Ganti air	Ganti air	No Feeding			

		Before feeding		After feeding		Automatic feed schedule					
		Water pH	Water temperature	pH quality of water	Quality Water temperature	Giving 7.30	Giving 10.05	Giving 12.30	Giving 15.05	Giving 17.01	Giving 21.30
		6.64	27.25C	6.67	28.25C		okay				
		6.59	28.31C	6.59	28.62C				okay		
		5.44	28.06C	Ganti air	Ganti air						No Feeding
3	7-3-2023	7.06	27.44C	6.59	28.31C	okay					
		6.75	28.44C	6.75	28.44C		okay				
		6.59	28.81C	6.77	28.81C				okay		
		6.71	28.69C	7.24	28.62C						okay
4	7-4-2023	4.91	28.25C	Ganti air	Ganti air	No Feeding					
		6.54	27.13C	6.35	28.19C		okay				
		5.6	29.44C	Ganti air	Ganti air						No Feeding
		6.74	29.00C	8.1	28.81C						okay
5	7-5-2023	7.01	27.50C	7.15	27.19C	okay					
		6.7	28.31C	6.64	28.81C		okay				
		6.59	28.81C	6.78	29.50C				okay		
		7.12	28.81C	5.59	28.62C						okay

Table 2 Feeding 6x after sorting

Age	Date	Before feeding		After feeding		Automatic feed schedule					
		Water pH	Water temperature	pH quality of water	Quality Water temperature	Giving 7.30	Giving 10.05	Giving 12.30	Giving 15.05	Giving 17.01	Giving 21.30
11	7-11-2023	sorting	sorting	sorting	sorting	sorting					
		sorting	sorting	sorting	sorting		sorting				
		puasa	puasa	puasa	puasa				puasa		
		puasa	puasa	puasa	puasa					puasa	
		puasa	puasa	puasa	puasa						puasa
		puasa	puasa	puasa	puasa						
12	7-12-2023	4.92	26.31C	Ganti Air	Ganti Air	No Feeding					
		6.46	26.75C	7.05	26.75C		okay				
		7.21	27.06C	7.18	27.69C			okay			
		error	error	error	error					error	
		6.82	29.87C	6.98	28.87C						okay
		6.82	28.69C	7.03	28.62C						
13	7-13-2023	7.3	26.69C	7.28	26.75C	okay					
		7.21	27.06C	7.05	26.75C		okay				
		7.28	26.75C	7	28.38C			okay			
		7.14	28.56C	7.2	28.56C				okay		
		7.18	28.56C	6.99	28.87C					okay	
		6.99	28.87C	6.53	28.50C						okay

The growth in average weight of catfish was obtained based on the total weight of catfish during the research experiment on an 80 L drum with a total of 80 fish of:

Calculating the average weight of catfish:

$$\text{Fish average weight} = \frac{\text{Total Weight of Catfish}}{\text{Number of Catfish Samples}}$$

Catfish biomass was calculated to determine the capacity or capacity of an 80 L drum for a total sample of 80 catfish which were used as the first research sample based on their average weight. Based on the calculation of catfish biomass, the initial biomass of catfish weighed 4,070 grams and the average weight of catfish was 50.9 grams. Sorting is carried out to minimize poor water quality, cannibalism of fish of different sizes and adjusting the capacity of the 80 L drum because the total weight of catfish until the age of ten is 7,410 grams with an average weight of catfish 92 grams, after sorting the fish will be fasted 8-10 hours to avoid stress fish. then re-weighing was carried out with a total sample of 50 catfish which were used as the second research sample based on their average weight. Based on the results of catfish biomass calculations, the initial biomass of catfish weighed 4,665 grams and the average weight of catfish was 90.3 grams. Fish biomass on the twentieth day gained a weight of 5,900 grams with an average weight of 128 grams with the death of 4 catfish.

IV. CONCLUSIONS

1. Intensive Catfish Automatic Feeding Design Based on the Internet of Things works optimally according to the schedule automatically with the conditions of time and the amount of weight of feed given according to the percentage of catfish biomass.
2. Intensive Catfish Automatic Feeding Design Based on the Internet of Things can respond to commands and send feed control data automatically and monitor catfish age periodically in the telegram bot application.
3. Test results on an intensive automatic feeding system for catfish can respond to commands or send water quality data in an 80 L drum by monitoring two sensors, namely pH and temperature, good water conditions for catfish in an 80 L drum, namely a pH value of 6-8 and a temperature of 26-29°C. If the pH and temperature in the water are less than these conditions, the catfish's appetite will decrease, causing the catfish's health to decrease so that there is an immediate notification "Change water" so do a water change immediately.
4. The results of an intensive automatic feeding system for catfish in an 80 L drum using the Close loop control system method were obtained in the first experiment by feeding 4x in a day the initial catfish biomass was 4,070 grams and the average weight of catfish was 50.9 grams up to the tenth age, a biomass of 7,410 grams was obtained with an average catfish weight of 92 grams. After that, 50 catfish were sorted by feeding 6x a day, the eleventh day biomass was 4,665 grams and the average catfish weight was 90.3 grams. Until the fish biomass on the twentieth day was 5,900 grams with an average weight of 128 grams with the death of 4 catfish

ACKNOWLEDGMENT

All academicians of Institut Teknologi Telkom Surabaya.

REFERENCES

- [1] I. R. M. Kusuma, "UTOMATIC FEEDING FISH SYSTEM PENERAPAN TEKNOLOGI PEMBERIAN PAKAN IKAN OTOMATIS PADA KELOMPOK PETANI TAMBAK MINA ABADI," vol. 12, no. 2007, pp. 703–712, 2014, [Online]. Available: <https://hsgm.saglik.gov.tr/depo/birimler/saglikli-beslenme-hareketli-hayat-db/Yayinlar/kitaplar/diger-kitaplar/TBSA-Beslenme-Yayini.pdf>
- [2] deri derii siregar, "PENGARUH BEBERAPA JENIS PAKAN ALAMI TERHADAP PERTUMBUHAN DAN KELANGSUNGAN HIDUP BENIH IKAN LELE SANGKURIANG (Clarias sp)," <http://repository.dharmawangsa.ac.id/>, 2020. <http://repository.dharmawangsa.ac.id/379/> (accessed Jul. 21, 2023).
- [3] A. Qalit and A. Rahman, "Rancang Bangun Prototipe Pemantauan Kadar Ph Dan Kontrol Suhu Serta Pemberian Pakan Otomatis Pada Budidaya Ikan Lele Sangkuriang Berbasis Iot," J. Karya Ilm. Tek. Elektro, vol. 2, no. 3, pp. 8–15, 2017.
- [4] Ita Apriyani, "Budidaya Ikan Lele Sistem Bioflok: Teknik Pembesaran Ikan Lele Sistem BioflokKelola Mina Pembudidaya," <https://books.google.co.id/>, 2017. <https://books.google.co.id/books?id=i109DwAAQBAJ> (accessed Jul. 21, 2023).
- [5] F. Hidayat, A. Harijanto, and B. Supriadi, "RANCANG BANGUN ALAT UKUR SISTEM MONITORING pH DAN SUHU KOLAM IKAN LELE BERBASIS IoT DENGAN ESP8266," J. Kumparan Fis., vol. 5, no. 2, pp. 77–84, 2022, doi: 10.33369/jkf.5.2.77-84.
- [6] Suparyanto dan Rosad (2015, "Rancang Bangun Sistem Filtering Air Pada Budidaya Ikan Lele Berdasarkan Kekerusuhan Menggunakan Sensor Turbidity," Suparyanto dan Rosad (2015, vol. 5, no. 3, pp. 248–253, 2020.