

Monitoring System On LoRa Protocol-Based Aquaponics With RSSI And Packet Loss Parameters (Case Study: Rooftop ITTelkom Surabaya)

1st Fitria Rahma Wulandari
Faculty of Information Technology and
Business
Institut Teknologi Telkom Surabaya
Surabaya, Indonesia
fitriarahma@student.ittelkom-sby.ac.id

2nd Helmy Widyantara
Faculty of Information Technology and
Business
Institut Teknologi Telkom Surabaya
Surabaya, Indonesia
helmywid@ittelkom-sby.ac.id

3rd Khodijah Amiroh
Faculty of Information Technology and
Business
Institut Teknologi Telkom Surabaya
Surabaya, Indonesia
dijaamirah@ittelkom-sby.ac.id

Abstract—Population density makes it difficult to find enough green space to meet food needs, which is a prevalent issue in metropolitan areas. So one of the urban agricultural techniques that might offer a solution is aquaponics. This technology combines hydroponics and aquaculture to allow for the simultaneous cultivation of fish and crops. Water quality is crucial to aquaponics, thus it needs to be routinely checked. Aquaponic water can be monitored in real-time using internet of things technology, however most of the time wifi is used, which has a range of just about 45 meters. The LoRa protocol is used in this study to send aquaponic water data since it has a long transmission range of 10-15 kilometers and uses little power, allowing it to last for up to 10–20 years. The PH-4502C temperature sensor, the TDS SEN022 sensor, and the DS18B20 temperature sensor will all provide data on the monitored aquaponic water quality. The sensor data is then processed by the Arduino Uno microcontroller and transferred using the LoRa protocol by the LoRA LYNX-32 board. The Telkom IoT LoRa gateway subsequently receives the data and displays it on the Telkom IoT Platform website. Data transmission was evaluated at 18 location locations by assessing RSSI and packet loss in order to determine the position inside the ITTelkom Surabaya Campus region and the effectiveness in transferring data using the LoRa protocol. Within a 200-meter radius, there were RSSI readings ranging from -89.94 dBm to -110.03 dBm with packet losses between 10% and 33%. RSSI falls into two categories: moderate (67%), and bad (33%). Good category packet loss is 22%, medium category packet loss is 61%, and terrible category packet loss is 17%. Due to the sensitivity of radio waves on LoRa, various circumstances, such the presence of buildings, trees, and other obstructions, can cause variations in RSSI values and packet loss. The area around the ITTelkom Surabaya Campus is deemed to be a good location for using the LoRa protocol to convey data in real time on the internet of things since it has an 81% success rate, according to the study's findings.

Keywords—Aquaponics, LoRa, RSSI, Packet Loss.

I. INTRODUCTION

Indonesia is an agricultural country with a dense population. The population of Indonesia will increase by around three million people in 2023, from 278.69 million to 275.77 million, according to the BPS or Central Bureau of Statistics [1]. Because of this, in addition to purchasing food from farmers, the town may also produce its own crops and raise its own fish to meet its food demands. The population growth is likewise correlated with an increase in the need for food.

Population density makes it difficult to find enough green space to meet food needs, which is a prevalent issue in metropolitan areas. Therefore, urban farming is the answer. Aquaponics is a method of urban farming that combines hydroponics and aquaculture to grow vegetables while raising fish. In aquaponics, these two elements are crucial for the life of fish and plants because they are intimately tied to water. Aquaponics uses water that, as it flows through the pond, mixes with fish excrement and leftover feed to produce natural fertilizer and nutrients for plants. The air will then pass through the plant roots, acting as a natural air filter to clean the air before it returns to the pond [2]. As a result, it is necessary to regularly monitor the pH, temperature, and other dissolved components in aquaponic water.

Aquaponic monitoring has never been simpler thanks to the Internet of Things (IoT), which enables real-time monitoring. A pH sensor, a TDS (Total Dissolve Solid) sensor to measure dissolved substances in the air, and a temperature sensor are among the sensors required. IoT devices often use WiFi to send data, but without any obstacles, WiFi can only transmit data up to 45 meters [3]. The LoRa protocol or lengthy distances with a range of 10-15 kilometers can be used for longer data transmission. LoRa also has the benefit of using less power, allowing it to last for 10 to 20 years. Even though it only transmits data at a rate of between 0.3 and 50 kbps, this is not a problem for sending sensor data [4].

Researchers will monitor the water quality in aquaponic systems at 18 locations around the ITTelkom Surabaya campus, and the data will be communicated via LoRa. In order to determine the RSSI quality and packet loss from the 18 locations evaluated, the test material in this study focuses on assessing the reception of data sent using the RSSI (Received Signal Strength Indicator) and packet loss parameters.

II. THEORY

A. Aquaponics

Urban farming can benefit from the use of aquaponics. By maximizing the use of water and the limited available area, this technology integrates two systems, namely hydroponics and aquaculture, to allow for simultaneous crop and fish cultivation. Using water circulation from the fish pond to flow into the hydroponic growing medium and then back to the fish pond, aquaponics achieves its desired results. The water that drains from the pond will mix with fish waste and leftover feed to create natural fertilizer for the aquatic

plants that grow above it. Meanwhile, the water that passes through the roots of the plants will naturally filter and can be cleaned of toxic substances so that the water returns to the pond in a clean and healthy condition. fish survival is possible [9].

Plants that can be grown in water growing media are appropriate for aquaponic systems. Kale, mustard greens, pakcoy, and lettuce are plants that are frequently grown in aquaponic systems. While catfish, tilapia, catfish, carp, and carp are the fish that are frequently grown in aquaponic systems [10]. In terms of survival, these two components are extremely connected to water. To grow properly, fish require water that is between 25 and 28 degrees Celsius and has a pH between 6.5 and 9. Additionally, hydroponic plants require a pH of 7 in order to efficiently absorb nutrients and develop to their full potential [11]. This necessitates routine aquaponic water monitoring using technology to increase effectiveness and efficiency.



Figure I. Aquaponics

B. Temperature Sensor DS18B20

DS18B20 sensor is a digital and waterproof temperature sensor issued by Dallas Semiconductor. This sensor can measure temperatures from -55 °C to 125 °C, although it is not advised to use it at temperatures above 100 °C. Heat can be turned into energy via this sensor. The DS18B20 has a DC supply voltage of 3-5.5 volts, a 9-bit ADC resolution, and an accuracy of 0.5 °C (in the range of -10 °C to 85 °C) [12].



Figure II. Temperature Sensor DS18B20

C. Sensor pH- 4502C

The analog pH sensor pH-4502C measures pH. A probe connector and a module make up this sensor. The module has 6 pins total: To, Do, Po, 2 GND pins, and VCC. The module is powered by 5 volts. This sensor features an LED as an excessive power alert and can detect pH values between 0 and 14. The sensor needs to be calibrated before use in order to acquire reliable pH results [13].



Figure III. Sensor pH-4502C

D. Sensor TDS SEN0244

The amount of dissolved organic and inorganic compounds in a solution is measured using the TDS (Total Dissolved Solid) sensor, a digital sensor. Parts per million, or ppm, is the unit used to express the TDS sensor value. This sensor has an output voltage range of 0–2.3 volts and an input voltage range of 3.3–5.5 volts. This sensor can measure values between 0 and 1000 ppm [14].



Figure IV. Sensor TDS SEN0244

E. Arduino Uno

Arduino Uno is an Atmega 328-based microcontroller board which has 14 digital input/output pins, 6 analog input pins, a power jack, a reset button, an ICSP header, and a 16 Mhz crystal oscillator. This microcontroller can be connected to a computer using a USB cable with an AC to DC adapter or a battery. The operating voltage used is 5 volts DC [15].

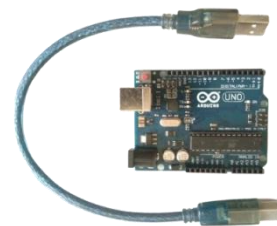

Figure V. Arduino Uno

F. Arduino IDE (Integrated Development Environment)

Arduino IDE is software used to create, edit program code and can be verified and uploaded to the microcontroller. This software consists of a text editor that functions to create and edit program code, toolbars, text consoles, and buttons with other common functions. Programs created on the Arduino IDE will be named sketch and saved with the .ino extension [16].

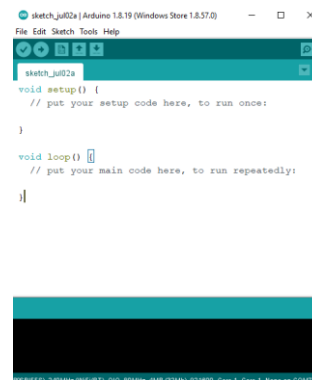

Figure VI. Arduino IDE

G. LoRa Antares

LoRa or Long Range is an open source wireless communication system for the internet of things. In Indonesia, LoRa operates in the 920-923 MHz frequency band. LoRa can reach 10-15 kilometers and has the advantage of low power, namely 13mA – 15mA, so it can be used for up to 10-20 years. Data transmission speed in LoRa is relatively low, which is around 0.3 – 50 kbps, but it is not a problem when the data sent is small in size such as sensor data [17]. LoRa is built using a star to star topology so that it allows the device to work using a battery for a long time. The LoRa architecture consists of end-nodes, gateways, network servers, and application servers. End-nodes are devices that are connected directly to sensors and can receive or send information using LoRa. The gateway functions as a connecting bridge from the end-nodes to the network server or vice versa. The network server functions as a controller that controls several gateways. Application servers can accommodate several applications that can be accessed by users [18].



Figure VII. LoRa Antares

H. Telkom IoT Platform

Telkom IoT Platform is an IoT technology service developed by PT. Telekomunikasi Indonesia and can be accessed at <https://console.telkomiot.id/>. This platform can connect, manage, and automate various sensors and display data and visualize on personal dashboards. The Telkom IoT platform can be accessed using three protocols namely LoRa, MQTT, and HTTP [20].



Figure VIII. Telkom IoT Platform

I. RSSI (Received Signal Strength Indicator)

RSSI is an indicator for wireless devices in terms of received signal strength. There are several things that can affect signal strength such as interference, noise, and multipath fading that can affect the RSSI value. The unit of RSSI is dBm with a range of -10dBm to approximately -100dBm. The better the signal quality is the closer to the positive value. Table 2.2 shows the standardization of signal strength values according to THIPON (Telecommunication and IP Harmonization Over Network) [21].

Signal Strength (dBm)	Category
> - 70	Very Good
-70 to -85	Good
-86 to -100	Moderate
<-100	Ugly

J. Packet Loss

Packet loss is the number of packets lost when sending data. Some of the causes of packet loss are due to collisions, congestion, overflow, or errors that occur on the physical media.

$$\text{Packet loss} = \frac{(\text{packet sent} - \text{packet received})}{\text{packet received}} \times 100\%$$

The following table is a packet loss categorization based on the THIPON standard.

Packet Loss (%)	Category
0-2	Very Good
3-14	Good
15-24	Moderate
>25	Ugly

III. METHODS

A. Diagram Block

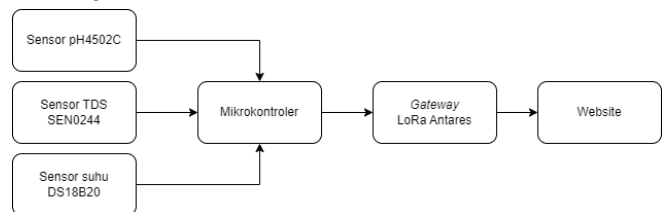

Figure IX. Diagram Block

This study used three sensors, namely the pH-4502C sensor, the TDS SEN0244 sensor, and the DS18B20 temperature sensor. When all of these sensors are immersed in aquaponic water, they produce a signal in the form of data that will be processed by the Arduino Uno microcontroller. The data obtained will be sent to the Antares LoRa gateway device. After that the data will be displayed on the Telkom IoT Platform website display.

B. Hardware Design

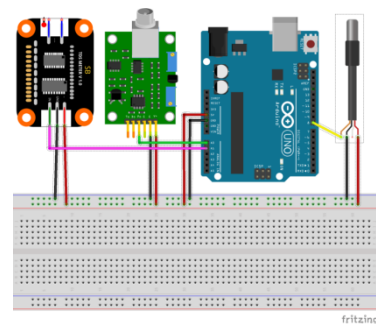

Figure X. Hardware Design

The picture above is the hardware design used. starting from the far left are the TDS sensor, pH sensor, arduino uno, and temperature sensor.

C. Flowchart System

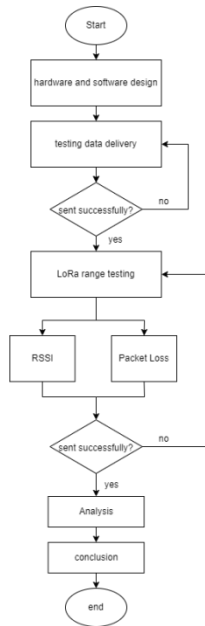

Figure XI. Flowchart System

This research starts with hardware design in the form of an IoT tool, namely pH, TDS, and temperature sensors as well as LoRa devices. Then test the delivery of data that will be displayed on the website. If the data is successfully sent, a LoRa distance test will be carried out. If the data cannot be sent, it will be sent again. Testing the location of sending data using the LoRa protocol is carried out by varying locations in the ITTelkom Surabaya Campus area to get an effective location for sending data. Supporting parameters to be analyzed are RSSI and packet loss. After that the results will be analyzed to draw conclusions.

IV. RESULT AND DISCUSSION

A. Hardware Implementation

PH, TDS, and temperature sensors are connected to Arduino Uno which acts as a microcontroller. This circuit requires the help of a breadboard to connect the ground pin and the 5V pin from Arduino to the sensors so that the sensors get power. Then from Arduino Uno it sends data to the LoRa board. The LoRa board and Arduino Uno get power from a power bank to work. The microcontroller will work with a command so that it can read the sensor and send data.

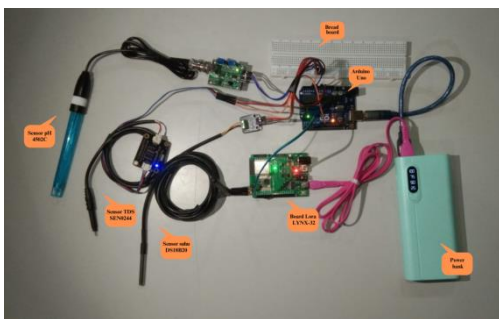

Figure XII. Hardware Implementation

B. Website Appearance

Data that has been successfully sent will be displayed on the website and will appear in real time.

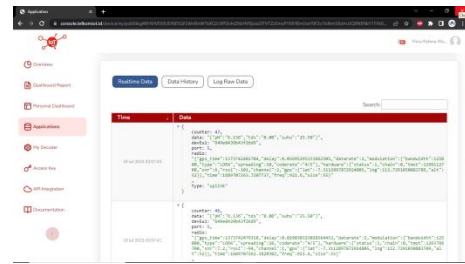

Figure XIII. Hardware Implementation

C. Data Collection

Data collection was carried out at 18 points in the ITTelkom Surabaya campus area. These areas are Rooftop Warung, Greenhouse, Gazebo, Takhobbar Mosque, Behind Telkom Office, Wifi corner, Front security post, Motorcycle parking area, Volleyball court, Front of workshop, Next to War Stadium Badminton, Car parking area, Behind War Stadium Tennis, Court flag, Front court, Floor 2, Floor 1 (Lab. 1.26), Ground Floor (Lobby). Each point is taken RSSI data and packet loss. Data will be sent every 3 seconds and the test is carried out for 2 minutes at each point, so the data sent is 40 data.

No	Point	Environmental Conditions	Average RSSI (dBm)	Packet Loss (%)	Altitude (masl)
1	Rooftop shop	Open, roofed, on top of a 3rd floor building	-105,82	15	20
2	Greenhouse	Open, between the greenhouses, at the top of the 3rd floor building	-105,83	13	20
3	Gazebo	Open, there is a large lush tree	-95,97	18	7
4	Takhobar Mosque	Open, roofed, close to the wall, placed on the floor	-110,03	13	7
5	Behind the Telkom office	Open, there are several trees with lush leaves, close to the buildings and iron pillars	-93,70	33	7
6	Wifi corner	Open, there are several trees with lush leaves, placed on the iron table	-95,30	25	7
7	Front guard post	It's open, near the security post building	-100,64	10	7
8	Motorcycle parking area	Open, roofed, lots of motorbikes	-94,83	25	7

9	Volley ball court	Open, there are several trees but not dense	-93,15	18	7
10	Workshop front	Open, near the vehicle	-99,41	20	7
11	Next to war stadium badminton	Open, near buildings, laid on the ground	-95,06	20	7
12	Car parking area	It's open, there are a few trees, lots of cars, laid out on the ground	-95,90	23	7
13	Behind the tennis court	Open, near buildings, laid on the ground	-104,42	18	7
14	Flag field	Open, near the building, set on a metal chair	-100,26	23	7
15	Front field	Open, not many obstacles, placed on the ground	-89,94	15	7
16	2nd Floor	Closed, near the hallway	-97,51	13	16
17	1st floor	Closed, indoors, lots of computers	-96,28	20	12
18	Ground floor	Closed, placed on an iron chair	-97	18	7

V. CONCLUSIONS

From the research that has been done, it can be concluded that:

1. The data communication system using the LoRa protocol on the internet of things in the ITTelkom Surabaya campus area using LoRa Antares will be sent to Telkom IoT's LoRa Gateway and can be monitored via the Telkom IoT Platform website in real time with an 81% success rate.
2. The use of the LoRa protocol network in data communication on the internet of things in the ITTelkom Surabaya campus area is quite effective because it can transmit data at various points with RSSI values between -89.94dBm to -110.03dBm and packet loss between 10% - 33 %. RSSI in the moderate category is 67%, while the bad category is 33%. Packet loss with good category is 22%, medium category is 61%, and bad category is 17%.
3. The best location for aquaponics monitoring is at the front guard post based on the packet loss parameter of 10%, while based on the RSSI the best location for

placing aquaponics is at the front of the field at -89.94dBm.

4. LoRa is very sensitive to obstacles and the height between the transmitter and receiver so that it becomes one of the causes of loss of LoRa signals, so it is necessary to consider placing a LoRa module with a LoRa Gateway.

ACKNOWLEDGMENT

All academicians of Institut Teknologi Telkom Surabaya.

REFERENCES

- [1] <https://www.bps.go.id/indicator/12/1975/1/jumlah-penduduk-pertengahan-tahun.html>. diakses pada 29 Juni 2023 pukul 13.31
- [2] N. A. Rokhmah, et al., "Vertiminaponik, Mini Akuaponik Untuk Lahan Sempit Di Perkotaan", vol. 2, no. 4, pp. 100-101, 2020.
- [3] P. K. D. Cahya, et al., "Perancangan Jaringan Local Area Network (LAN) Untuk Layanan Video Conference Dengan Standar Wifi 802.11g", vol. 2, 2019.
- [4] D. T. Adin, et al., "Sistem Monitoring Parameter Fisik Air Kolam Ikan menggunakan Jaringan Sensor Nirkabel berbasis Protokol LoRa", vol. 3, no. 6, 2019.
- [5] S. R. Rafidah, A. Wagiyana, "Rancang Bangun Sistem Pemantau dan Pengendali Nutrisi Tanaman Hidroponik Berbasis Modul Long Range (LoRa)", vol. 1, 2020.
- [6] H. Muchtar, et al., "Desain Pembuatan Alat Pemantauan Temperatur dan Kelembaban dengan Menggunakan Teknologi LoRa", vol. 5, no. 2, 2021.
- [7] A. Yanziyah, S. Soim, M. M. Rose, "Analisis Jarak Jangkauan LoRa Dengan Parameter RSSI dan Packet Loss pada Area Urban", vol. 13, no. 1, 2020.
- [8] E. Murdyantoro, I. Rosyadi, H. Septian, "Studi Performansi Jarak Jangkauan LoRa OLG01 Sebagai Infrastruktur Konektivitas Nirkabel IoT", vol. 15, no. 1, 2019.
- [9] L. E. Rahmadhani, L. I. Widuri, and P. Dewanti, "Kualitas Mutu Sayur Kasepak (Kangkung, Selada, dan Pakcoy)", J. Agroteknologi, vol. 14, no. 01, pp. 33-43, 2020.
- [10] D. Megawati, et al., "Rancang Bangun Sistem Monitoring PH dan Suhu Air pada Akuaponik Berbasis Internet of Thing (IoT)" vol. 6, no. 2, pp. 124-137, 2020.
- [11] Y. Sastro, "Teknologi Akuaponik Mendukung Pengembangan Urban Farming", vol. 5, no. 7, 2020.
- [12] D. T. Adin, et al., "Sistem Monitoring Parameter Fisik Air Kolan Ikan Menggunakan Jaringan Sensor Nirkabel berbasis Protokol LoRa", vol. 3, no. 6, 2019.
- [13] I. A. Rozaq, N. Y. D. Setyaningsih, "Karakterisasi Dan Kalibrasi Sensor Ph Menggunakan Arduino Uno", prosiding SENDI_U, pp. 244-245, 2019.
- [14] A. R. Susanto, et al., "Implementasi Sistem Gateway Discovery pada Wireless Sensor Network (WSN) Berbasis Modul Komunikasi LoRa", vol. 3, no. 2, 2019
- [15] T. A. Siswanto, M. A. Rony, "Aplikasi Monitoring Suhu Air Untuk Budidaya Ikan Koi Dengan Menggunakan Mikrokontroler Arduino Nano Sensor Suhu DS18B20 Waterproof Dan Peltier Tec1-12706 pada Dunia Koi", vol. 1, no. 1, 2019.
- [16] S. Samsugi, et al., "Sistem Pengontrol Irigasi Otomatis Menggunakan Mikrokontroler Arduino Uno", vol. 1, no. 1, 2020.
- [17] H. Effendi, R. Puspitaningrum, "Rancang Bangun Sistem Monitoring Pemakaian Air Pam Dan Mutu Air Pada Komplek Perumahan Dengan Jaringan Nirkabel Lora Berbasis Arduino Uno", vol. 23, no. 1, pp. 50-51, 2021.
- [18] A. Yanziyah, S. Soim, M. M. Rose, "Analisis Jarak Jangkauan LoRa Dengan Parameter RSSI dan Packet Loss pada Area Urban", vol. 13, no. 1, 2020.
- [19] A. R. Susanto, et al., "Implementasi Sistem Gateway Discovery pada Wireless Sensor Network (WSN) Berbasis Modul Komunikasi LoRa" vol. 3. No. 2, 2019.
- [20] S. N. Agni, et al., "Correlation of Relationship Business Model and Business Strategy: Case Study PT Telkom IoT", 2022.

- [21] T. S. J. Putra, "Analisis Kualitas Signal Wireless Berdasarkan Received Signal Strength Indicator (RSSI) pada Universitas Kristen Satya Wacana", 2019.
- [22] M. Huda, Jusak, "Analisis Karakteristik Lalu Lintas Data Internet: Aplikasi Web Social Network", vol. 4, no. 2, 2019.

IEEE conference templates contain guidance text for composing and formatting conference papers. Please ensure that all template text is removed from your conference paper prior to submission to the conference. Failure to remove template text from your paper may result in your paper not being published.

We suggest that you use a text box to insert a graphic (which is ideally a 300 dpi TIFF or EPS file, with all fonts embedded) because, in an MSW document, this method is somewhat more stable than directly inserting a picture.

To have non-visible rules on your frame, use the MSWord "Format" pull-down menu, select Text Box > Colors and Lines to choose No Fill and No Line.