

DAFTAR PUSTAKA

- [1] A. K. Ridwanuddin, K. Anwar, and A. Sugiana, "STUDI INTERFERENSI ANTARA FUTURE RAILWAY MOBILE COMMUNICATION SYSTEMS (FRMCS) DAN GSM SELULER DI INDONESIA."
- [2] C. Ahmadi, S. Bali, J. Raya, P. N. 86, and R. Denpasar, "ANALISIS KAPASITAS KANAL TERHADAP JUMLAH ANTENA PADA SISTEM MIMO (MULTIPLE INPUT MULTIPLE OUTPUT)," 2015.
- [3] S. H. Triwibowo, E. Wahyudi, and S. Larasati, "Perbandingan Penggunaan Teknik Diversity pada Jaringan Gelombang Mikro di Lingkungan Danau."
- [4] U. Sulistiyani, U. Kurniawan Usman, and B. Syihabuddin, "ANALISA KOMUNIKASI MM-WAVE BERBASIS HYBRID BEAMFORMING ANALYSIS MM-WAVE BASE ON HYBRID BEAMFORMING."
- [5] Z. Liu, M. Yang, J. Cui, Y. Xiao, and X. Zhang, "Performance and Capacity Optimization for High Speed Railway Communications Using UAV-IRS Assisted Massive MIMO System," *Electronics (Switzerland)*, vol. 12, no. 11, Jun. 2023, doi: 10.3390/electronics12112547.
- [6] Z. Lei *et al.*, "Experimental evaluation of 4G technologies in metro tunnel scenarios," in *2016 10th European Conference on Antennas and Propagation, EuCAP 2016*, Institute of Electrical and Electronics Engineers Inc., May 2016. doi: 10.1109/EuCAP.2016.7481740.
- [7] A. Yudha Bagaskara, B. Bagus, and R. Diana, "PERANCANGAN ANTENA MIKROSTRIP RECTANGULAR PATCH SEBAGAI PENERIMA TELEVISI."
- [8] "Cross-border coordination and synchronisation for Railway Mobile Radio (RMR) networks in the 1900-1910 MHz TDD frequency band."
- [9] A. S. Irtawaty, M. Ulfah, and H. Hadiyanto, "Pengaruh Beamwidth, Gain dan Pola Radiasi terhadap Performansi Antena Penerima," *JTT (Jurnal*

Teknologi Terpadu), vol. 6, no. 1, p. 14, Apr. 2018, doi: 10.32487/jtt.v6i1.434.

- [10] F. Solehudin, Y. Kurnia Ningsih, and S. Alam, “PERANCANGAN ANTENA MIKROSTRIP ARRAY MULTIPLE INPUT MULTIPLE OUTPUT (MIMO) 4 ELEMEN DENGAN SLITS DAN SLOTS DESIGN MICROSTRIP ANTENNA ARRAY MULTIPLE INPUT MULTIPLE OUTPUT (MIMO) 4 ELEMENT WITH SLITS AND SLOTS.” [Online]. Available: <http://dinarek.unsoed.ac.id>
- [11] N. Noor Amalia, K. Anwar, and N. Mufti Adriansyah, “PENINGKATAN KINERJA FUTURE RAILWAY MOBILE COMMUNICATION SYSTEM UNTUK KERETA CEPAT INDONESIA DENGAN SINGLE INPUT MULTIPLE OUTPUT-DOPPLER SPREAD COMPENSATOR,” 2021.
- [12] “Perancangan Antena MIMO 2x2 dengan Penambahan Struktur Electromagnetic Band Gap (EBG) pada Frekuensi 2.1 GHz.”
- [13] A. Dwi Satya, E. Yovita Dwi Utami, A. A. Febrianto, and U. Kristen Satya Wacana, “Perancangan dan Realisasi Antena Mikrostrip Persegi Panjang MIMO pada Frekuensi 15 GHz.”
- [14] R. J. Hendra, Y. Rahayu, and E. Safrianti, “ANALISIS ANTENA MIKROSTRIP ARRAY BENTUK LINGKARAN DAN PERSEGI PANJANG MENGGUNAKAN SIMULASI UNTUK APLIKASI LTE FREKUENSI 2.3 GHZ,” 2015.
- [15] G. Wibisono and F. Tito Andarto, “Perancangan dan Simulasi Low Noise Amplifier untuk Penerima Automatic Picture Transmission dan High Resolution Picture Transmission.”
- [16] R. Dwi Wibisono and Y. Christyono, “PERANCANGAN MODULATOR DAN DEMODULATOR QUADRATURE PHASE SHIFT KEYING (QPSK) DENGAN RANGKAIAN BALANCE MODULATOR.”

LAMPIRAN CD-1

Lampiran 1 : Spesifikasi USRP B200/B210

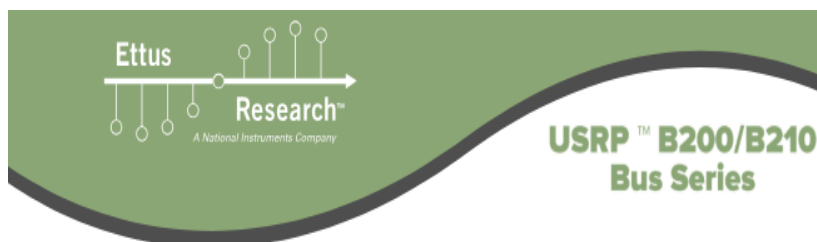

Spec	Typ.	Unit
Power		
DC Input	6	V
Conversion Performance and Clocks		
ADC Sample Rate (max)	61.44	MS/s
ADC Resolution	12	bits
ADC Wideband SFDR	78	dBc
DAC Sample Rate (max)	61.44	MS/s
DAC Resolution	12	bits
Host Sample Rate (16b)**	61.44	MS/s
Frequency Accuracy	±2.0	ppm
W/ GPS Unlocked TCXO Reference	±75	ppb
W/ GPS Locked TCXO Reference	< 1	ppb

Spec	Typ.	Unit
RF Performance (single channel)		
SSB/LO Suppression	-35/50	dBc
3.5 GHz	1.0	deg RMS
6 GHz	1.5	deg RMS
Power Output	>10	dBm
IIP3 (@ typ NF)	-20	dBm
Receive Noise Figure	<8	dB
Physical		
Dimensions	9.7x15.5x1.5	cm
Weight	350	g

*All specifications are subject to change without notice.

** See benchmark results for sample rates in various configurations.

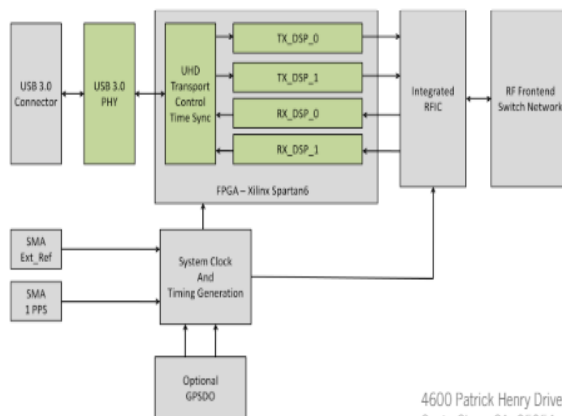

Lampiran 2: Perbandingan GSM-R dan FRMCS

GSM-R	FRMCS
Global System for MOBILE Communication - Railway	Future Railway Mobile Communication System
2G	5G
900 MHz	900 / 1900 MHz
Circuit Switched	Packet Switched (IP)
Voice / Data	MCX: Voice / Data / Video
Low data volume:	High data volume: > 1 Gbit/s
High latency: 500 ms	Low latency: 30 ms
Since 2002 in operation ...	from 2026 on ... (planning)

LAMPIRAN CD-2

Lampiran 1: Regulasi ECC Frekuensi 1900 MHz



Cross-border coordination and synchronisation for Railway Mobile Radio (RMR) networks in the 1900-1910 MHz TDD frequency band

approved 16 June 2023

Lampiran 2: Jarak antara *Base station Transmitter*

Scenario name	Model and speed	ISD (km)	Neighbour cell load (trains)
Urban	Urban (80 km/h)	2	6
High Density	Urban (80 km/h)	4	4
High speed 1	Rural (350 km/h)	4	2
High speed 2	Rural (350 km/h)	6	2
High speed 3	Rural (350 km/h)	8	2

LAMPIRAN CD-3

Lampiran 1: Melakukan sidang seminar proyek



Lampiran 2: Pabrikasi antenna



LAMPIRAN CD-4

Lampiran 1: Pemasangan masting antenna untuk pengukuran



Lampiran 2: Pengukuran Parameter Antena

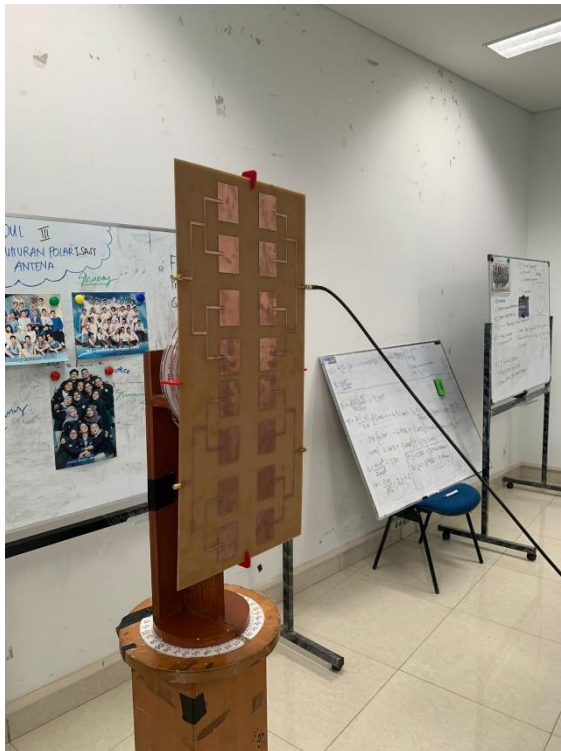

Lampiran 3: Pengambilan Data dari VNA



Lampiran 4: Pengambilan Data Return Loss dan VSWR



Lampiran 5: Pengujian Menggunakan Antena *Horn*



Lampiran 6: Plotting Data dari VNA ke Laptop



Lampiran 7: Mengikuti Pameran *Capstone* di Gedung TULT



Lampiran 8: Hasil Pengambilan Data Polaradiasi Port 1

AZIMUTH

PORT 1	1	2	3	Rata Rata	MAX
0	-64,043	-64,367	-64,709	-64,373	-64,043
10	-69,189	-68,635	-68,205	68,67633	-68,205
20	-76,566	-77,609	-77,135	77,10333	-76,566
30	-81,234	-79,643	-79,059	79,97867	-79,059
40	-73,658	-73,449	-72,868	-73,325	-72,868
50	-76,905	-77,609	-78,62	77,71133	-76,905
60	-74,064	-72,104	-73,301	73,15633	-72,104
70	-72,84	-72,55	-72,487	72,62567	-72,487
80	-77,715	-77,956	-78,403	78,02467	-77,715
90	-74,214	-73,505	-73,478	73,73233	-73,478
100	-75,847	-77,789	-77,902	77,17933	-75,847

110	-85,899	-89,839	-85,464	-	87,06733	-85,464
120	-81,869	-80,431	-79,886	-	80,72867	-79,886
130	-83,947	-84,353	-84,978	-	-84,426	-83,947
140	-66,28	-66,132	-66,339	-	66,25033	-66,132
150	-67,591	-67,395	-67,347	-	67,44433	-67,347
160	-67,775	-66,287	-66,775	-	66,94567	-66,287
170	-64,785	-64,35	-64,245	-	-64,46	-64,245
180	-66,296	-66,671	-66,956	-	-66,641	-66,296
190	-63,027	-63,108	-63,212	-	63,11567	-63,027
200	-60,991	-61,189	-61,894	-	-61,358	-60,991
210	-60,909	-61,817	-61,9	-	-61,542	-60,909
220	-62,368	-62,589	-61,674	-	62,21033	-61,674
230	-61,251	-62,697	-63,908	-	62,61867	-61,251
240	-68,486	-69,474	-68,482	-	-68,814	-68,482
250	-69,061	-69,906	-68,076	-	69,01433	-68,076
260	-64,927	-64,686	-65,78	-	-65,131	-64,686
270	-61,877	-61,928	-62,417	-	-62,074	-61,877
280	-61,985	-63,436	-63,754	-	63,05833	-61,985
290	-68,497	-69,451	-68,873	-	68,94033	-68,497
300	-65,091	-66,169	-67,197	-	66,15233	-65,091
310	-64,648	-64,324	-64,508	-	64,49333	-64,324
320	-64,003	-64,443	-63,884	-	-64,11	-63,884
330	-63,936	-63,302	-63,251	-	63,49633	-63,251
340	-62,596	-63,186	-62,481	-	62,75433	-62,481
350	-64,415	-63,005	-62,609	-	-63,343	-62,609

ELEVASI

PORT 1	1	2	3	Rata Rata	MAX
0	-49,283	-49,256	-49,407	-	-49,256
10	-49,812	-49,934	-49,581	-	-49,581

20	-52,125	-52,233	-52,202	-	52,18667	-52,125
30	-58,371	-58,248	-58,056	-58,225	-58,225	-58,056
40	-67,343	-67,92	-67,3	-67,521	-67,521	-67,3
50	-64,559	-65,26	-64,505	-	64,77467	-64,505
60	-63,441	-63,344	-63,156	-	63,31367	-63,156
70	-65,318	-65,982	-64,95	-	65,41667	-64,95
80	-66,139	-66,039	-66,286	-	66,15467	-66,039
90	-72,803	-71,332	-71,617	-	71,91733	-71,332
100	-72,036	-71,93	-72,191	-	72,05233	-71,93
110	-69,868	-69,444	-69,976	-	69,76267	-69,444
120	-82,662	-80,024	-80,938	-81,208	-81,208	-80,024
130	-70,555	-70,021	-69,252	-	69,94267	-69,252
140	-64,453	-64,915	-64,419	-	64,59567	-64,419
150	-61,22	-61,293	-61,319	-	61,27733	-61,22
160	-59,959	-60,013	-60,079	-60,017	-60,017	-59,959
170	-57,206	-57,118	-57,09	-57,138	-57,138	-57,09
180	-52,515	-52,271	-52,335	-	52,37367	-52,271
190	-52,997	-53,394	-53,352	-	53,24767	-52,997
200	-54,252	-54,545	-54,6	-	54,46567	-54,252
210	-59,567	-60,105	-60,236	-	59,96933	-59,567
220	-73,322	-72,48	-72,175	-72,659	-72,659	-72,175
230	-72,014	-73,693	-73,372	-	73,02633	-72,014
240	-77,153	-75,911	-76,92	-	76,66133	-75,911
250	-64,972	-67,487	-65,539	-	65,99933	-64,972
260	-64,876	-65,218	-65,472	-	65,18867	-64,876
270	-71,914	-71,717	-71,373	-71,668	-71,668	-71,373
280	-72,421	-71,792	-72,827	-	72,34667	-71,792
290	-70,488	-71,17	-70,166	-70,608	-70,608	-70,166

300	-65,406	-64,518	-63,842	-	64,58867	-63,842
310	-69,276	-68,116	-68,178	-	68,52333	-68,116
320	-77,365	-76,442	-74,398	-	76,06833	-74,398
330	-70,673	-70,338	-69,398	-	70,13633	-69,398
340	-64,438	-63,116	-64,375	-	63,97633	-63,116
350	-54,411	-54,888	-54,472	-	54,59033	-54,411

Lampiran 9: Hasil Pengambilan Data Polaradiasi Port 2

PORT 2	1	2	3	Rata Rata	MAX	
0	-64,499	-62,962	-62,875	-	63,44533	-62,875
10	-66,979	-67,746	-68,216	-67,647	-66,979	-66,979
20	-75,261	-74,86	-72,469	-	74,19667	-72,469
30	-69,199	-68,925	-69,404	-69,176	-68,925	-68,925
40	-68,103	-69,323	-70,567	-69,331	-68,103	-68,103
50	-68,65	-68,945	-68,448	-68,681	-68,448	-68,448
60	-69,041	-67,921	-68,145	-68,369	-67,921	-67,921
70	-67,383	-66,59	-67,738	-67,237	-66,59	-66,59
80	-68,839	-68,714	-68,821	-	68,79133	-68,714
90	-66,142	-67,29	-66,92	-66,784	-66,142	-66,142
100	-67,823	-70,37	-69,446	-69,213	-67,823	-67,823
110	-73,533	-73,281	-71,464	-	72,75933	-71,464
120	-73,122	-72,213	-71,764	-	72,36633	-71,764
130	-71,601	-71,596	-69,449	-70,882	-69,449	-69,449
140	-74,839	-74,666	-74,712	-74,739	-74,666	-74,666
150	-69,493	-62,962	-62,875	-65,11	-62,875	-62,875
160	-69,24	-71,254	-70,337	-70,277	-69,24	-69,24
170	-67,463	-67,591	-67,097	-	67,38367	-67,097
180	-67,876	-67,985	-68,154	-68,005	-67,876	-67,876
190	-68,465	-68,446	-67,66	-	68,19033	-67,66
200	-68,589	-70,409	-71,814	-	70,27067	-68,589
210	-72,424	-72,351	-73,174	-	72,64967	-72,351

220	-69,891	-68,414	-68,257	-68,854	-68,257
230	-69,244	-69,082	-69,442	-69,256	-69,082
240	-77,921	-76,5	-77,841	- 77,42067	-76,5
250	-68,41	-69,587	-70,262	- 69,41967	-68,41
260	-62,302	-62,714	-63,049	- 62,68833	-62,302
270	-58,401	-58,015	-58,666	- 58,36067	-58,015
280	-57,789	-57,6	-57,721	- 57,70333	-57,6
290	-57,425	-58,037	-57,289	- 57,58367	-57,289
300	-63,048	-63,153	-63,283	- 63,16133	-63,048
310	-70,858	-69,452	-68,053	- 69,45433	-68,053
320	-67,52	-66,885	-67,374	- 67,25967	-66,885
330	-61,409	-60,202	-60,149	- 60,58667	-60,149
340	-58,185	-59,969	-60,392	- 59,51533	-58,185
350	-59,592	-58,024	-58,194	- 58,60333	-58,024
PORT 2	1	2	3	Rata Rata	MAX
0	-49,491	-49,4	-49,244	- 49,37833	-49,244
10	-50,179	-49,635	-49,51	- 49,77467	-49,51
20	-53,548	-53,322	-53,233	- 53,36767	-53,233
30	-59,408	-59,939	-59,781	- 59,70933	-59,408
40	-72,29	-73,1	-72,316	- 72,56867	-72,29
50	-69,535	-68,899	-68,924	- 69,11933	-68,899
60	-64,85	-64,609	-64,62	-64,693	-64,609
70	-68,434	-68,087	-68,121	-68,214	-68,087
80	-72,573	-72,467	-70,433	- 71,82433	-70,433
90	-68,13	-68,429	-69,013	-68,524	-68,13
100	-73,215	-75,909	-73,869	-74,331	-73,215
110	-70,152	-70,766	-70,537	-70,485	-70,152
120	-65,444	-66,058	-65,833	- 65,77833	-65,444

130	-63,303	-63,156	-63,192	-63,217	-63,156
140	-64,236	-64,379	-64,42	-64,345	-64,236
150	-60,171	-60,817	-60,717	-	-60,171
				60,56833	
160	-60,209	-60,326	-60,076	-	-60,076
				60,20367	
170	-58,368	-58,039	-57,733	-	-57,733
				58,04667	
180	-54,407	-54,271	-54,214	-	-54,214
				54,29733	
190	-57,04	-57,857	-57,568	-	-57,04
				57,48833	
200	-55,852	-55,961	-56,191	-	-55,852
				56,00133	
210	-61,85	-61,437	-61,493	-	-61,437
				61,59333	
220	-74,654	-73,51	-72,088	-	-72,088
				73,41733	
230	-64,181	-63,888	-63,302	-	-63,302
				63,79033	
240	-66,879	-65,144	-66,261	-	-65,144
				66,09467	
250	-62,199	-62,865	-62,663	-	-62,199
				62,57567	
260	-63,199	-62,238	-62,785	-	-62,238
				62,74067	
270	-65,879	-64,157	-64,077	-	-64,077
				64,70433	
280	-73,234	-75,828	-75,609	-	-73,234
				74,89033	
290	-62,933	-63,806	-64,745	-63,828	-62,933
300	-65,488	-64,572	-66,087	-	-64,572
				65,38233	
310	-76,526	-77,399	-76,064	-76,663	-76,064
320	-68,887	-69,032	-69,581	-	-68,887
				69,16667	
330	-69,106	-70,677	-68,803	-	-68,803
				69,52867	
340	-68,581	-67,556	-67,616	-	-67,556
				67,91767	
350	-52,969	-52,372	-52,428	-	-52,372
				52,58967	

Lampiran 10: Hasil Pengambilan Data Polaradiasi Port 3

PORT 3	1	2	3	Rata Rata	MAX
0	-60,66	-60,325	-60,43	-	-60,325
				60,47167	

10	-61,062	-62,25	-63,47	-	62,26067	-61,062
20	-64,481	-63,177	-63,072	-	63,57667	-63,072
30	-62,127	-61,879	-61,781	-61,929		-61,781
40	-59,418	-59,835	-60,201	-59,818		-59,418
50	-60,84	-59,548	-60,302	-60,23		-59,548
60	-63,203	-64,304	-64,001	-63,836		-63,203
70	-66,363	-65,626	-64,784	-65,591		-64,784
80	-69,175	-68,906	-69,417	-69,166		-68,906
90	-65,014	-64,074	-66,113	-65,067		-64,074
100	-65,087	-65,51	-63,434	-64,677		-63,434
110	-61,336	-62,123	-62,496	-61,985		-61,336
120	-65,608	-66,85	-66,967	-66,475		-65,608
130	-66,83	-68,915	-67,008	-	67,58433	-66,83
140	-65,534	-65,255	-68,258	-66,349		-65,255
150	-64,636	-64,684	-64,81	-64,71		-64,636
160	-68,887	-67,164	-69,537	-	68,52933	-67,164
170	-70,164	-70,333	-69,891	-	70,12933	-69,891
180	-66,903	-65,798	-64,932	-	65,87767	-64,932
190	-64,099	-64,391	-65,13	-64,54		-64,099
200	-65,579	-65,126	-64,49	-65,065		-64,49
210	-61,33	-69,069	-68,844	-	66,41433	-61,33
220	-68,048	-69,663	-69,929	-	69,21333	-68,048
230	-71,869	-71,909	-70,117	-	71,29833	-70,117
240	-70,048	-71,504	-71,374	-	70,97533	-70,048
250	-75,665	-71,719	-72,998	-	73,46067	-71,719
260	-71,735	-71,322	-70,064	-	71,04033	-70,064
270	-70,308	-70,704	-70,169	-	70,39367	-70,169
280	-67,306	-66,987	-67,741	-	67,34467	-66,987
290	-64,895	-64,422	-64,944	-	64,75367	-64,422
300	-66,768	-66,764	-66,053	-	66,52833	-66,053

310	-65,481	-64,712	-65,363	-	65,18533	-64,712
320	-64,074	-64,464	-64,611	-	-64,383	-64,074
330	-65,22	-65,072	-64,17	-	64,82067	-64,17
340	-64,935	-64,906	-65,594	-	-65,145	-64,906
350	-68,274	-69,884	-69,138	-	69,09867	-68,274
PORT 3	1	2	3		Rata Rata	MAX
0	-50,505	-50,141	-50,637	-	50,42767	-50,141
10	-51,508	-51,536	-51,439	-	51,49433	-51,439
20	-55,519	-54,799	-55,528	-	-55,282	-54,799
30	-62,254	-61,72	-62,26	-	-62,078	-61,72
40	-64,139	-63,688	-63,995	-	63,94067	-63,688
50	-67,895	-66,31	-66,857	-	67,02067	-66,31
60	-67,574	-69,742	-69,398	-	68,90467	-67,574
70	-65,165	-63,262	-63,34	-	63,92233	-63,262
80	-63,977	-63,841	-64,168	-	63,99533	-63,841
90	-76,72	-74,039	-73,989	-	-74,916	-73,989
100	-67,301	-69,156	-66,348	-	67,60167	-66,348
110	-65,509	-65,715	-66,132	-	65,78533	-65,509
120	-64,507	-62,793	-62,777	-	-63,359	-62,777
130	-66,062	-65,208	-62,764	-	-64,678	-62,764
140	-61,414	-61,422	-61,017	-	61,28433	-61,017
150	-67,381	-67,005	-66,729	-	67,03833	-66,729
160	-69,48	-69,599	-69,803	-	69,62733	-69,48
170	-65,177	-63,676	-64,772	-	64,54167	-63,676
180	-60,864	-61,827	-61,058	-	61,24967	-60,864
190	-55,57	-55,282	-55,94	-	55,59733	-55,282
200	-55,057	-54,742	-55,485	-	55,09467	-54,742
210	-55,425	-55,725	-55,451	-	55,53367	-55,425

220	-60,442	-60,899	-59,021	-	60,12067	-59,021
230	-69,836	-69,085	-69,837	-69,586	-	-69,085
240	-69,233	-69,344	-68,836	-	69,13767	-68,836
250	-69,779	-71,145	-69,588	-	70,17067	-69,588
260	-70,334	-71,694	-71,72	-	71,24933	-70,334
270	-64,671	-65,195	-63,741	-	64,53567	-63,741
280	-62,417	-62,734	-62,272	-	62,47433	-62,272
290	-70,027	-70,737	-69,962	-70,242	-	-69,962
300	-70,723	-70,369	-72,311	-	71,13433	-70,369
310	-66,77	-65,936	-66,445	-	66,38367	-65,936
320	-61,328	-61,574	-61,704	-	61,53533	-61,328
330	-61,154	-60,953	-61,85	-61,319	-	-60,953
340	-56,656	-56,923	-57,198	-	56,92567	-56,656
350	-51,525	-51,534	-51,218	-	51,42567	-51,218

Lampiran 11: Hasil Pengambilan Data Polaradiasi Port 4

PORT 4	1	2	3	Rata Rata	MAX
0	-65,549	-64,212	-64,226	-	64,66233
10	-68,06	-68,534	-64,832	-67,142	-64,832
20	-65,715	-66,656	-67,507	-66,626	-65,715
30	-65,185	-66,598	-67,094	-	66,29233
40	-62,626	-62,876	-61,878	-62,46	-61,878
50	-67,802	-63,054	-62,162	-	64,33933
60	-66,356	-66,583	-66,317	-	66,41867
70	-78,564	-76,043	-75,34	-76,649	-75,34
80	-66,415	-67,027	-63,477	-	65,63967
90	-63,798	-63,561	-64,182	-63,847	-63,561
100	-63,564	-65,701	-66,118	-	65,12767

110	-68,763	-70,677	-69,647	-	69,69567	-68,763
120	-67,504	-67,462	-66,53	-	67,16533	-66,53
130	-59,751	-60,268	-59,446	-	59,82167	-59,446
140	-60,849	-60,142	-59,589	-	60,19333	-59,589
150	-65,4	-64,904	-64,76	-	65,02133	-64,76
160	-85,83	-86,157	-87,171	-	-86,386	-85,83
170	-68,619	-70,507	-70,067	-	-69,731	-68,619
180	-68,705	-69,951	-65,211	-	67,95567	-65,211
190	-66,298	-66,581	-66,869	-	66,58267	-66,298
200	-71,047	-71,801	-71,529	-	-71,459	-71,047
210	-71,114	-71,913	-71,396	-	71,47433	-71,114
220	-66,927	-67,964	-67,942	-	-67,611	-66,927
230	-64,057	-64,405	-64,215	-	64,22567	-64,057
240	-63,8	-64,682	-62,128	-	63,53667	-62,128
250	-67,809	-65,554	-65,754	-	66,37233	-65,554
260	-64,976	-63,638	-64,037	-	-64,217	-63,638
270	-69,877	-70,22	-70,14	-	-70,079	-69,877
280	-71,232	-71,453	-72,483	-	71,72267	-71,232
290	-73,211	-70,82	-71,875	-	71,96867	-70,82
300	-63,557	-63,609	-63,489	-	63,55167	-63,489
310	-63,157	-63,365	-63,196	-	63,23933	-63,157
320	-64,681	-64,662	-64,256	-	-64,533	-64,256
330	-63,5	-64,804	-65,388	-	-64,564	-63,5
340	-62,492	-63,553	-63,434	-	63,15967	-62,492
350	-65,928	-66,198	-65,581	-	65,90233	-65,581
PORT 4	1	2	3	Rata Rata	MAX	
0	-51,32	-51,588	-51,751	-51,553	-51,32	
10	-53,073	-53,123	-52,811	-	53,00233	-52,811
20	-57,836	-57,806	-57,935	-	-57,859	-57,806
30	-83,105	-84,706	-84,567	-	-84,126	-83,105

40	-66,368	-68,784	-66,485	-	67,21233	-66,368
50	-66,088	-65,645	-66,294	-66,009		-65,645
60	-74,808	-74,276	-74931	-	25026,69	-74,276
70	-75,366	-75,945	-74,225	-	75,17867	-74,225
80	-68,759	-69,871	-70,107	-69,579		-68,759
90	-64,961	-64,419	-63,537	-	64,30567	-63,537
100	-63,892	-64,136	-64,002	-64,01		-63,892
110	-67,265	-67,102	-66,336	-66,901		-66,336
120	-62,71	-62,501	-63,169	-	62,79333	-62,501
130	-63,382	-64,67	-65,528	-	64,52667	-63,382
140	-66,741	-66,721	-66,508	-	66,65667	-66,508
150	-72,542	-73,943	-72,505	-	72,99667	-72,505
160	-69,931	-70,14	-71,14	-	70,40367	-69,931
170	-60,014	-61,188	-60,43	-60,544		-60,014
180	-57,944	-58,304	-58,164	-	58,13733	-57,944
190	-55,461	-54,701	-54,266	-	54,80933	-54,266
200	-54,644	-54,143	-53,875	-	54,22067	-53,875
210	-54,48	-54,514	-54,456	-	54,48333	-54,456
220	-57,947	-58,062	-57,415	-57,808		-57,415
230	-67,289	-67,936	-67,51	-	67,57833	-67,289
240	-65,842	-66,418	-66,94	-66,4		-65,842
250	-67,063	-67,731	-68,226	-	67,67333	-67,063
260	-72,442	-73,063	-73,336	-72,947		-72,442
270	-65,423	-65,707	-65,72	-	65,61667	-65,423
280	-69,121	-68,432	-69,017	-	68,85667	-68,432
290	-74,505	-74,361	-73,352	-	74,07267	-73,352
300	-66,865	-66,884	-66,898	-	66,88233	-66,865
310	-66,63	-66,65	-66,283	-66,521		-66,283
320	-63,815	-63,672	-63,772	-63,753		-63,672

330	-73,331	-73,687	-73,466	- 73,49467	-73,331
340	-59,464	-59,902	-59,439	- 59,60167	-59,439
350	-54,667	-54,957	-55,141	- 54,92167	-54,667

LAMPIRAN CD-5

Lampiran 1: Proses Integrasi USRP B200 dengan PC



Lampiran 2: Proses Menghubungkan USRP dengan PC

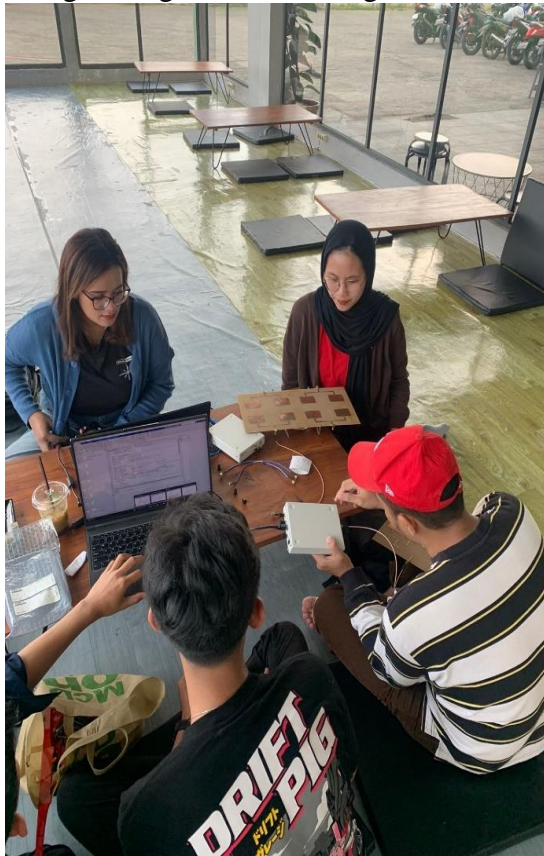

Lampiran 3: Pengujian Antena Tx dan Rx



Lampiran 4: Pengujian Antena Tx dan Rx Menggunakan USRP b200 di Laboratorium



Lamprian 5: Script MATLAB Blok Transmitter

```

function SimParams = sdrupsktransmitter_init(platform, address, sampleRate, centerFreq, gain, captureTime)
platform = 'B200'; % Platform USRP
address = '31DFF26'; % Address USRP
sampleRate = 1e6; % 1 MHz sample rate
centerFreq = 1900e6; % 1900 MHz center frequency
gain = 10; % Gain dB setting
captureTime = 10; % Capture time in seconds

%% General simulation parameters
SimParams.ModulationOrder = 4; % QPSK alphabet size
SimParams.Interpolation = 2; % Interpolation factor
SimParams.Decimation = 1; % Decimation factor
SimParams.Fs = sampleRate; % Sample rate
SimParams.Rsym = sampleRate/SimParams.Interpolation; % Symbol rate in Hertz
SimParams.Tsym = 1/SimParams.Rsym; % Symbol time in sec

%% Frame Specifications
SimParams.BarkerCode = [+1 +1 +1 +1 -1 -1 +1 +1 -1 -1 +1]; % Bipolar Barker Code
SimParams.BarkerLength = length(SimParams.BarkerCode);
SimParams.HeaderLength = SimParams.BarkerLength * 2; % Duplicate 2 Barker codes to be as a header
SimParams.Message = 'ANTENA MIMO TRANSMITTER';
SimParams.MessageLength = length(SimParams.Message) + 5; % 'ANTENA MIMO TRANSMITTER 000\n'...
SimParams.NumberOfMessage = 10; % Number of messages in a frame
SimParams.PayloadLength = SimParams.NumberOfMessage * SimParams.MessageLength * 7; % 7 bits per characters
SimParams.FrameSize = (SimParams.HeaderLength + SimParams.PayloadLength) ...
    / log2(SimParams.ModulationOrder); % Frame size in symbols
SimParams.FrameTime = SimParams.Tsym*SimParams.FrameSize;

%% Tx parameters
SimParams.RolloffFactor = 0.5; % Rolloff Factor of Raised Cosine Filter
SimParams.ScalerBase = 2;
SimParams.ScalerPolynomial = [1 1 1 0 1];
SimParams.ScalerInitialConditions = [0 0 0 0];
SimParams.RaisedCosineFilterSpan = 10; % Filter span of Raised Cosine Tx filters (in symbols)

%% Message generation
msgSet = zeros(100 * SimParams.MessageLength, 1);
for msgCnt = 0 : 99
    msgSet(msgCnt * SimParams.MessageLength + (1 : SimParams.MessageLength)) = ...
        sprintf('%s %03d\n', SimParams.Message, msgCnt);
end
bits = de2bi(msgSet, 7, 'left-msb');
SimParams.MessageBits = bits(:);

%% USRP transmitter parameters
SimParams.Platform = platform;
SimParams.Address = address;

switch platform
case {'B200', 'B210'}
    SimParams.MasterClockRate = 20e6; % Hz
case {'X300', 'X310'}
    SimParams.MasterClockRate = 200e6; % Hz
case {'N300', 'N310'}
    SimParams.MasterClockRate = 125e6; % Hz
case {'N320/N321'}
    SimParams.MasterClockRate = 200e6; % Hz
case {'N200/N210/USRP2'}
    SimParams.MasterClockRate = 100e6; % Hz
otherwise
    error(message('sdr:examples:UnsupportedPlatform', platform))
end
SimParams.USRPCenterFrequency = centerFreq;
SimParams.USRPGain = gain;
SimParams.USRPFrontEndSampleRate = SimParams.Rsym * 2; % Nyquist sampling theorem
SimParams.USRPInterpolationFactor = SimParams.MasterClockRate/SimParams.USRPFrontEndSampleRate;
SimParams.USRPFrameLength = SimParams.Interpolation * SimParams.FrameSize;

% Experiment Parameters
SimParams.USRPFrameTime = SimParams.USRPFrameLength/SimParams.USRPFrontEndSampleRate;
SimParams.StopTime = captureTime;

end

```

Lampiran 6: Script MATLAB Blok Receiver

```

function SimParams = sdruQPSKReceiverSInit(platform,useCodegen,isHDLcompatible)
platform = 'B200'; % Platform
address = '31DFF26'; % Address
sampleRate = 1e6; % 1 MHz sample rate
centerFreq = 1900e6; % 1900 MHz center frequency
gain = 10; % Gain setting
captureTime = 20; % Capture time in seconds

%% General simulation parameters
SimParams.Fs = sampleRate; % Sample rate
SimParams.ModulationOrder = 4; % QPSK alphabet size
SimParams.Interpolation = 2; % Interpolation factor
SimParams.Decimation = 1; % Decimation factor
SimParams.Rsym = sampleRate/SimParams.Interpolation;
SimParams.Tsym = 1/SimParams.Rsym; % Symbol time in sec

%% Frame Specifications
SimParams.BarkerCode = [+1 +1 +1 +1 -1 -1 +1 +1 -1 -1 +1]; % Bipolar Barker Code
SimParams.BarkerLength = length(SimParams.BarkerCode);
SimParams.HeaderLength = SimParams.BarkerLength * 2; % Duplicate 2 Barker codes to be as a header
SimParams.Message = 'ANTENA MIMO TRANSMITTER';
SimParams.MessageLength = length(SimParams.Message) + 5; % 'Hello world 000\n'...
SimParams.NumberOfMessage = 10; % Number of messages in a frame
SimParams.PayloadLength = SimParams.NumberOfMessage * SimParams.MessageLength * 7; % 7 bits per characters
SimParams.FrameSize = (SimParams.HeaderLength + SimParams.PayloadLength) ...
    / log2(SimParams.ModulationOrder); % Frame size in symbols
SimParams.FrameTime = SimParams.Tsym*SimParams.FrameSize;

%% Rx parameters
SimParams.RolloffFactor = 0.5; % Rolloff Factor of Raised Cosine Filter
SimParams.ScramblerBase = 2;
SimParams.ScramblerPolynomial = [1 1 1 0 1];
SimParams.ScramblerInitialConditions = [0 0 0 0];
SimParams.RaisedCosineFilterSpan = 10; % Filter span of Raised Cosine Tx Rx filters (in symbols)
SimParams.DesiredPower = 2; % AGC desired output power (in watts)
SimParams.AveragingLength = 50; % AGC averaging length
SimParams.MaxPowerGain = 60; % AGC maximum output power gain
SimParams.MaximumFrequencyOffset = 6e3;
% Look into model for details for details of PLL parameter choice.
% Refer equation 7.30 of "Digital Communications - A Discrete-Time Approach" by Michael Rice.
K = 1;
A = 1/sqrt(2);
SimParams.PhaseRecoveryLoopBandwidth = 0.01; % Normalized loop bandwidth for fine frequency compensation
SimParams.PhaseRecoveryDampingFactor = 1; % Damping Factor for fine frequency compensation
SimParams.TimingRecoveryLoopBandwidth = 0.01; % Normalized loop bandwidth for timing recovery
SimParams.TimingRecoveryDampingFactor = 1; % Damping Factor for timing recovery
% K_p for Timing Recovery PLL, determined by 2KA^2*2.7 (for binary PAM),
% QPSK could be treated as two individual binary PAM,
% 2.7 is for raised cosine filter with roll-off factor 0.5
SimParams.TimingErrorDetectorGain = 2.7*2*K*A^2+2.7*2*K*A^2;
SimParams.PreambleDetectorThreshold = 0.8;

%% Message generation and BER calculation parameters
msgSet = zeros(100 * SimParams.MessageLength, 1);
for msgCnt = 0 : 99
    msgSet(msgCnt * SimParams.MessageLength + (1 : SimParams.MessageLength)) = ...
        sprintf('%s %03d\n', SimParams.Message, msgCnt);
end
bits = de2bi(msgSet, 7, 'left-msb');
SimParams.MessageBits = bits(:);

% For BER calculation masks
SimParams.BerMask = zeros(SimParams.NumberOfMessage * length(SimParams.Message) * 7, 1);
for i = 1 : SimParams.NumberOfMessage
    SimParams.BerMask( (i-1) * length(SimParams.Message) * 7 + ( 1 : length(SimParams.Message) * 7) ) = ...
        (i-1) * SimParams.MessageLength * 7 + (1 : length(SimParams.Message) * 7);
end

%% USRP receiver parameters
switch platform
case {'B200', 'B210'}
    SimParams.MasterClockRate = 20e6; % Hz
case {'X300', 'X310'}
    SimParams.MasterClockRate = 200e6; % Hz
case {'N200/N210/USRP2'}
    SimParams.MasterClockRate = 100e6; % Hz
case {'N300', 'N310'}
    SimParams.MasterClockRate = 125e6; % Hz
case {'N320/N321'}
    SimParams.MasterClockRate = 200e6; % Hz
otherwise
    error(message('sdru:examples:UnsupportedPlatform', ...
        platform))
end
SimParams.USRPCenterFrequency = 1900e6;
SimParams.USRPGain = 20;
SimParams.USRPFrontEndSampleRate = SimParams.Rsym * 2; % Nyquist sampling theorem
SimParams.USRPDecimationFactor = SimParams.MasterClockRate/SimParams.USRPFrontEndSampleRate;
SimParams.USRPFrameLength = SimParams.Interpolation * SimParams.FrameSize;

% Experiment parameters
SimParams.USRPFrameTime = SimParams.USRPFrameLength/SimParams.USRPFrontEndSampleRate;
SimParams.StopTime = 10;

```