

# COMMUNICATION SYSTEM BETWEEN CHARGING STATION AND ELECTRICAL VEHICLE USING POWER LINE COMMUNICATION

## SISTEM KOMUNIKASI ANTARA STASIUN PENGISIAN KENDARAAN LISTRIK DENGAN KENDARAAN LISTRIK MENGGUNAKAN KOMUNIKASI JARINGAN LISTRIK

Don Bosko Satria Yogsakti<sup>1</sup>, Alexander Tristan Daruz<sup>2</sup>, Raihany Afifa Augusta<sup>3</sup>, Reza Gustyan Sukmara<sup>4</sup>  
<sup>1,2,3,4</sup>Prodi S1 Teknik Elektro Kelas Internasional, Fakultas Teknik Elektro, Universitas Telkom  
<sup>1</sup>alextristan@student.telkomuniversity.ac.id, <sup>2</sup>donbosko@student.telkomuniversity.ac.id,  
<sup>3</sup>Raihany@student.telkomuniversity.ac.id, <sup>4</sup>rezagustyansukmara@student.telkomuniversity.ac.id

---

### Abstract

Electric vehicles are now starting to enter into a regular life, at least in its original sense of the word (for developing countries like Indonesia). In an electric vehicle, there is a little something called the Controlled Area Network (CAN) that serves as the central repository of how different parts in your car communicate with one another like sensors and part conditions. An electric vehicle always comes with a certain amount of charging, which is one of the very essential aspects of running properly. This would be advantageous if the vehicle had a means of communicating with the charging station to provide direct diagnostics on the vehicle's state while it is being charged by simply keeping up its routine maintenance. This is the major reason for the development of Electric Vehicle Power Line Communication (EVPLC). What is intended thereby, is to assure that a data transfer activity with a bidirectional communication mechanism can take place via the AC flowing over via the charging cable of the battery electric vehicle. Realizing the concept, researchers established an EVPLC module with emulated EVCS and EVCAN simulators through online simulation to show it can be deployed into a real electric vehicle (EV) charging station and car.

**Keywords :** CAN, Bidirectional, EVCS, EVCAN, AC

---

### Abstrak

Kendaraan listrik kini mulai memasuki kehidupan sehari-hari, setidaknya dalam arti aslinya (untuk negara berkembang seperti Indonesia). Di dalam kendaraan listrik, terdapat sesuatu yang disebut Controlled Area Network (CAN) yang berfungsi sebagai pusat penyimpanan informasi tentang bagaimana berbagai komponen di dalam mobil Anda berkomunikasi satu sama lain seperti sensor dan kondisi komponen. Kendaraan listrik selalu disertai dengan sejumlah pengisian daya, yang merupakan salah satu aspek yang sangat penting agar dapat berjalan dengan baik. Akan lebih menguntungkan jika kendaraan memiliki sarana untuk berkomunikasi dengan stasiun pengisian daya guna memberikan diagnostik langsung tentang kondisi kendaraan saat sedang diisi daya hanya dengan melakukan perawatan rutin. Inilah alasan utama pengembangan Electric Vehicle Power Line Communication (EVPLC). Tujuannya adalah untuk memastikan bahwa aktivitas transfer data dengan mekanisme komunikasi dua arah dapat berlangsung melalui arus bolak-balik yang mengalir melalui kabel pengisian daya kendaraan listrik bertenaga baterai. Mewujudkan konsep tersebut, para peneliti membuat modul EVPLC dengan simulasi simulator EVCS dan EVCAN melalui simulasi daring untuk menunjukkan bahwa modul tersebut dapat digunakan di stasiun pengisian daya kendaraan listrik (EV) dan mobil sungguhan.

**Kata Kunci:** CAN, Dua Arah, EVCS, EVCAN, AC

---

## 1. Introduction

### 1.1 Backgrounds

For years, electric vehicles have become a common part of everyday human life, especially in developed countries. This is driven by the efficiency and technological advancements provided by electric vehicles as well as the increasing awareness of a healthier way of life for the environment. In Indonesia, fossil fuel vehicles are still the public's favorite because most electric vehicles are still far from the reach of most Indonesian citizens due to their soaring prices, and the low desire to try new technological advances because people have been able to rely on fossil fuel vehicles for decades. However, there is growth in Indonesia, both in government and society, in the process of transitioning from fossil fuel vehicles to electric vehicles. Some people are already willing to replace their vehicles with electric vehicles, both cars and scooters, and the

government has made regulations that support the use of electric vehicles such as lower vehicle taxes, freedom from odd-even regulations, and even infrastructure that supports the use of electric vehicles such as the rapid growth of charging stations for electric vehicles [1]. These previous actions have created a growing momentum for the use of electric vehicles in Indonesia. In electric vehicles, there is an applied technology called CAN (Central Area Network) Bus. CAN-Bus is one type of automotive bus. Automotive bus is a communication network that connects automotive devices or underlying automotive instruments in a network within a vehicle. CAN bus was originally designed by Bosch in 1989 for automotive monitoring and control and is used in communication between the measurement and execution components of the car [2]. It can be concluded that CAN-Bus is a protocol that has a direct relationship with the components in the vehicle, meaning that through CAN-Bus, the current condition of the components in the vehicle can be observed. Based on a research document entitled "Development of an Electric Car Control System Based on CAN-BUS" by the National Institute of Technology, there are several components in electric vehicles that can be integrated with CAN-BUS [3]. These components are vehicle control systems, energy storage systems, motors and power inverters, charging station infrastructure, vehicle support systems, and transmissions. In this study, researchers focused on the energy storage system in electric vehicles. Because the wiring mechanism is already available through the implementation of CAN-Bus, this technology can be part of the implementation of Smart Grid in the electric vehicle industry through the existence of a gateway. This can be implemented through the existence of PLC (Power Line Communication). Power Line Communication (PLC) has several natural advantages that make it suitable for this type of application, such as the advantage of using the installed electrical network as a communication medium [4]. Unfortunately, EV-PLC technology is still rarely used in the market today, even in developed countries. By not using EV-PLC technology, users only need to go to a repair shop to analyze the condition of the EV thoroughly because not all electric vehicles are built with embedded networks that can analyze vehicle conditions, especially on electric motorbikes which have recently been widely used by drivers in Indonesia. Various types of electric vehicles can use different types of current and voltage levels that will affect the health of the battery in the long term. The combination of these two technologies can provide many benefits for electric vehicle users and industry because it allows them to analyze each connected component and reprogram it according to the user's wishes. Further developments, this technology can diagnose the components in the electric vehicle itself. In the previous year, a group of Telkom University students worked on a study entitled "Design of Public Electric Vehicle Charging Stations in the Telkom University Environment" [5]. From this research, the students created a charging station whose communication system via electric cables can be detected by the electric vehicle being applied. However, communication still works based on the principle of basic impedance. This research aims to form an electronic device that can be implemented in several types of charging stations and functions as a gateway technology between electronic vehicles and charging stations. Of course, by considering the IEC (International Electrotechnical Commission) standardization which is widely used for electric vehicles in Indonesia. Lately, there have been several companies that have created gateway technology

## **1.2 Requirements to be Fulfilled**

The needs that must be met based on the existing background are as follows:

1. The instrument can convert the given PLC signals into recognizable data for the EVCAN Simulator.
2. The instrument can communicate data bidirectionally between Electric Vehicle Charging Stations (EVCS) with an EVCAN Simulator.

## 1.3 Purpose

This paper introduces the development of an Electric Vehicle Power Line Communication (EVPLC) system specifically designed for Indonesia. The goal is to create a robust communication link between the Electric Vehicle Charging Station (EVCS) and the CAN Bus system on an electric vehicle. The system is designed to simplify wiring, improve safety, and facilitate real-time monitoring and diagnostics of vehicle components. The paper discusses the scarcity of locally manufactured EVPLC systems in Indonesia and highlights the advantages of integrating EVPLC with CAN Bus technology. Emphasizing functionality over aesthetics, the proposed solution focuses on improving data transmission accuracy, communication effectiveness, case durability, and programming efficiency. The main objectives include creating a reliable signal conversion instrument, ensuring compatibility with AC current, incorporating diagnostic features, encouraging domestic production, and enabling scalability. The paper also highlights how the proposed EVPLC system supports Indonesia's clean energy goals and contributes to the global goal of achieving Net Zero Emissions.

## 2. Supporting Information & System Design

### 2.1 Supporting Information

#### 2.1.1 KQ330 Powerline Communication Module

The KQ330 Powerline Communication (PLC) module is a device designed to transmit data over existing electrical wiring, enabling communication between devices without the need for additional wiring. Operating at low frequencies, the module is ideal for long-distance data transmission within buildings or across multiple structures. Specifically designed for reliable transmission of high-speed data in 0V-220V AC/DC and non-powered environments [8]. The module uses a proprietary modulation technique to encode data, ensuring reliable communication while minimizing interference. The KQ330 is compatible with standard electrical line voltages and is commonly used in applications such as smart grids, home automation, and remote monitoring. In your system, the module facilitates the transfer of sensor data between Arduinos by leveraging the existing power infrastructure, eliminating the need for additional communication cables.



Figure 2.1 KQ330

#### 2.1.2 MCP2515 CAN Bus Communication Module

The MCP2515 is a stand-alone CAN (Controller Area Network) controller module designed by Microchip Technology. It provides a means for devices to communicate over a CAN bus network, which is widely used in automotive and industrial applications for reliable, real-time data exchange between multiple microcontrollers or devices. The MCP2515 interfaces with a microcontroller via the Serial Peripheral Interface (SPI), enabling it to handle CAN protocol tasks, such as message filtering, prioritization, and transmission/reception of data frames. This module is often used in conjunction with a CAN transceiver, like the MCP2551, to physically connect to the CAN bus network. Its key features include support for high-speed (up to 1 Mbps) CAN communication,

built-in message buffering, and flexible configuration options, making it a versatile choice for integrating CAN capabilities into various electronic systems.

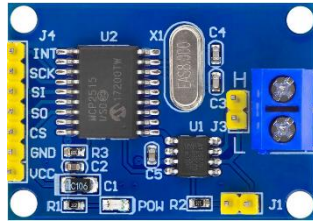

Figure 2.2 MCP2515

## 2.2 Product Requirements &

The requirements and during this research are summarized in the table below.

## Specifications

specifications that need to be fulfilled

Table 1. Research Requirements & Specification

No	Requirements	Specifications
1	The instrument can convert the given PLC signals into recognizable data for the EVCAN Simulator.	Specification 1: The given PLC signals can be recognized with CAN Bus Protocol as an embodiment of the EVCAN Simulator system.
2	The instrument can communicate data bidirectionally between Electric Vehicle Charging Stations (EVCS) with an EVCAN Simulator.	Specification 2: The instrument is capable of transferring and receiving data for the EVCS and EVCAN Simulator.

## 2.3 Solution Concept

### Overall Function

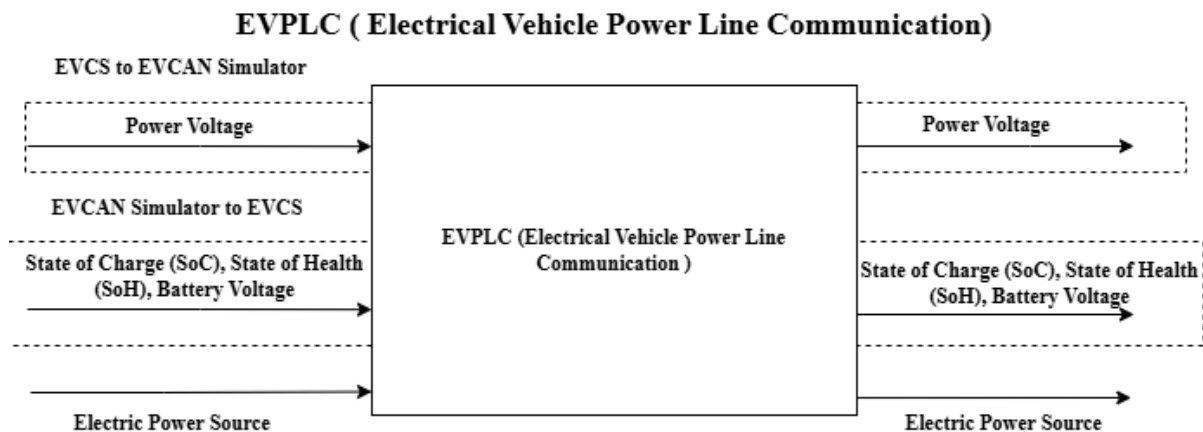

Figure 2. Overall Function EVPLC (Electrical Vehicle Power Line Communication)

Based on the function block diagram above (Figure 2), Overall Function of Electric Vehicle Powerline Communication, the Communication System in the system can be bidirectional therefore it has 2 inputs, the first input is Data from EVCS in the form of Power Voltage Data, and will produce output Power Voltage data that has been demodulated and will be displayed on the Control Pilot EV or HMI of EVCAN Simulator, then the second input is from the EV in the form of State of Charge (SoC), State of Health (SoH) and Battery Voltage

Data, and will produce data output State of Charge (SoC), State of Health (SoH) and Battery Voltage Data which will be displayed on the HMI from EVCS.

## 2.4 Chosen Components & System Design

Based on the previous information regarding the research requirements, specifications, and solution concepts, here is the list of the selected components to create a working EVPLC module. The list is shown in the table below.

Table 2. List of Selected Components

Selected Components	
Microcontroller	Arduino Nano
Case Material	Acrylic
LCD	I2C 20x4
PLC Module	KQ-330
CAN	MCP2515
Voltage Sensor	ZMPT101B
Power Supply	Power Bank
HMI (Human Machine Interface)	Nextion (NX4024K032_011)

For the system design, it would be a working PCB which can perform data communication with both CAN and AC current mechanism. The PCB would be placed inside of the EVPLC module casing as shown in the figure below.

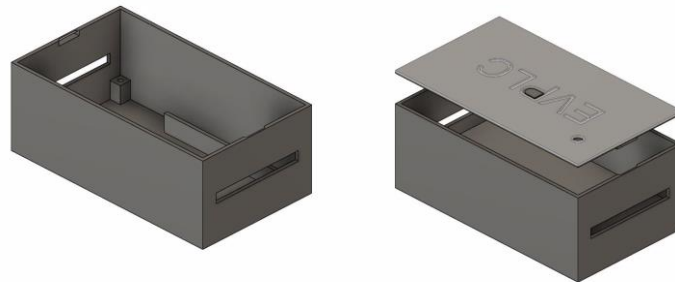

Figure 2.3 EVPLC Module Casing Design

## 3. Contents

### 3.1 Master Arduino Code Explanation

The Master arduino code sets up a bidirectional communication system using CAN bus and serial communication. The code initializes the CAN bus and serial interfaces in the `setup()` function. In the `loop()` function, it listens for CAN messages with a specific ID and data length to extract battery data, including state of charge (SoC), state of health (SoH), and battery voltage. When valid data is received, it sends this information via the KQ330 powerline communication module using `sendMessage()`. It then waits for a response, validates it, and sends the received voltage back over CAN bus to a connected device. Functions `sendMessage()` and `receiveMessage()` handle serial data transmission, while `validateMessage()` checks if the received data is non-empty.

### 3.2 Slave Arduino Code Explanation

This Arduino code implements the slave side of a bidirectional communication system using CAN bus and serial communication. In the `setup()` function, the CAN bus and serial interfaces are initialized. The `loop()` function monitors CAN messages for a specific ID to extract a voltage value. It then listens for incoming serial data using the `receiveMessage()` function, validates it, and parses it into separate battery data values (voltage, SoC, SoH) using `parseMessage()`. This data is then sent over CAN bus with a new message ID. The voltage value is also sent back to the master Arduino via the KQ330 powerline communication module using `sendMessage()`.

Functions `sendMessage()`, `receiveMessage()`, and `validateMessage()` handle serial data operations and validation, while `parseMessage()` processes the incoming string into usable data values.

### 3.3 EVCS Arduino Code Explanation

The EVCS Arduino code, integrates CAN bus communication, a voltage sensor, and a Nextion display. In the `setup()` function, it initializes serial communication for debugging and the Nextion display, sets up the ZMPT101B voltage sensor with a specified sensitivity, and configures the MCP2515 CAN controller with a 125

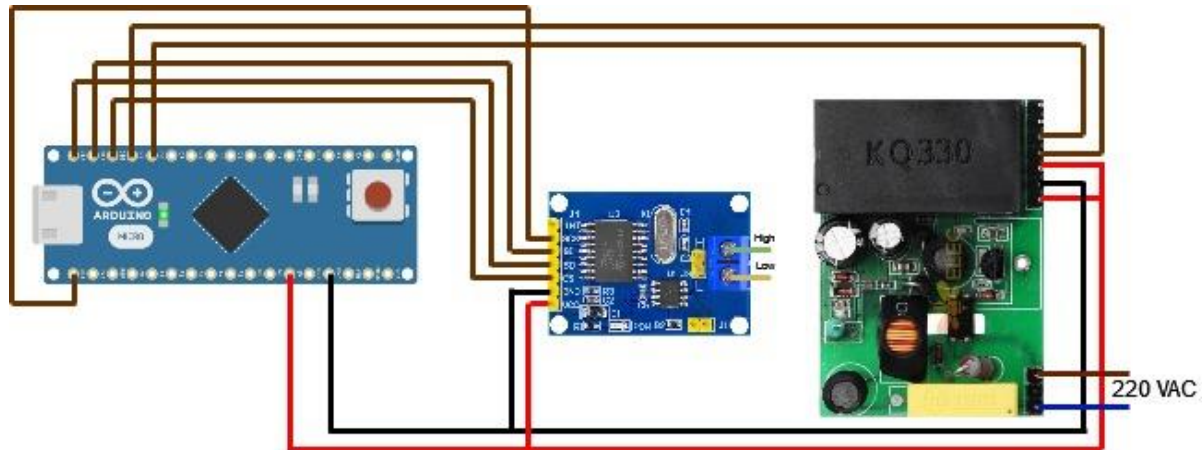

Figure 3. 1 Wiring Diagram of EVPLC Module

kbps bitrate. The `loop()` function processes incoming CAN messages with ID `0x200` and a DLC of 3, extracting battery data (voltage, state of charge, and state of health) and sending this information to the Nextion display using `SendToNextion()`, which formats commands and sends them through `sendCommand()`. It also reads the RMS voltage from the sensor, updates an LCD with this voltage, and transmits the voltage value via CAN bus with ID `0x100` and DLC of 1. This setup ensures that data from the voltage sensor is effectively communicated and displayed across the system.

## 4. Summary

The EVPLC (Electrical Vehicle Power Line Communication) Module is designed to advance the integration of electric vehicles (EVs) with charging infrastructure. The need for efficient communication between EVs and charging stations is critical for operational efficiency and vehicle management. The EVPLC module bridges this gap by utilizing power line communication in conjunction with the CAN (Controller Area Network) bus, which is standard for integrating sensors and data within electric vehicles. The module has been successfully tested with both the EVCAN Simulator and the EVCS Simulator, demonstrating its capability to facilitate AC communication between EV systems. This solution leverages coding for data transmission and reception, employing CAN bus protocols and serial communication through power lines. With further refinement, the EVPLC module is poised for implementation in real-world EV charging scenarios, enhancing real-time monitoring and system integration. This advancement opens new avenues for developing more robust and intelligent systems for electric vehicles, driving improvements in operational and diagnostic capabilities.

### Daftar Pustaka:

- [1] Biro Komunikasi dan Informasi Publik, "Pemerintah Terus Dorong Penggunaan Mobil Listrik," Kementerian Perhubungan Republik Indonesia.
- [2] J. N. Luo, C. M. Wu, and M. H. Yang, "A can-bus lightweight authentication scheme," *Sensors*, vol. 21, no. 21, Nov. 2021, doi: 10.3390/s21217069.
- [3] T. K. S. T. M.T., Dr. Waluyo MT., and S. S. T. M.T., "Pengembangan Sistem Kontrol Mobil Listrik Berbasis CAN-Bus," *IEEE*, 2016.
- [4] G. López *et al.*, "The role of power line communications in the smart grid revisited: Applications, challenges, and research initiatives," *IEEE Access*, vol. 7, pp. 117346–117368, 2019, doi: 10.1109/ACCESS.2019.2928391.
- [5] P. Stasiun and P. Kendaraan, "BUKU TUGAS AKHIR CAPSTONE DESIGN."

- [6] Akhila Nagaruru, "Understanding Controlled Area Network (CAN) for Automobile Industry needs," PATHPARTNER. Accessed: Oct. 20, 2023. [Online]. Available: <https://www.pathpartnertech.com/understanding-controlled-area-network-can-for-automobile-industry-needs/>
- [7] "CANBus: The Central Networking System Of Vehicles," premio. Accessed: Oct. 20, 2023. [Online]. Available: <https://premioinc.com/blogs/blog/can-bus-the-central-networking-system-of-vehicles>
- [8] Krishnan, Santosh. "KQ330 Power Line Communication." GitHub. Accessed September 3, 2024. <https://github.com/santoshkrishnanr/KQ330-power-line-communication->
- [9] Microchip Technology. "Stand-Alone CAN Controller with SPI Interface". November 29, 2011.