

Communication System Between Electric Vehicle and Electric Vehicle Charging Station Based on AC Powerline Carrier

Reza Gustyan Sukmara
Faculty of Electrical
Engineering
Telkom University
Bandung, Indonesia

rezagustyansukmara@student.telkomuniversity.ac.id

Irwan Purnama
Faculty of Electrical
Engineering
Telkom University
Bandung, Indonesia

Irwanpurnama@telkomuniversity.ac.id

Angga Rusdinar
Faculty of Electrical
Engineering
Telkom University
Bandung, Indonesia

Anggarusdinar@telkomuniversity.ac.id

Abstract

Electric vehicles are increasingly common in everyday life, especially in developed countries, while Indonesia is starting to adopt this concept. In electric vehicles, the Controller Area Network (CAN) serves as a central hub for data distribution throughout the vehicle, managing information from sensors, component status, and more. Charging is an important aspect of electric vehicles, which is crucial for the proper functioning of the vehicle. Establishing a communication link between the vehicle and the charging station offers significant benefits to both the user and the vehicle, enabling real-time diagnostics during routine charging. This is the driving force behind the development of Electric Vehicle Power Line Communication (EVPLC). The purpose of EVPLC is to enable data transfer through a two-way communication system via AC current used to charge the vehicle's battery. Researchers have developed an EVPLC module and validated the concept through simulations of an Electric Vehicle Charging Station (EVCS) and Electric Vehicle Controller Area Network (EVCAN). This approach aims to demonstrate the feasibility of implementing EVPLC in real-world charging stations and electric vehicles, ensuring efficient communication and diagnostics during the charging process.

Keywords : CAN, Bidirectional, EVCS, EVCAN, AC, electric vehicle.

1 Introduction

Electric vehicles (EVs) are increasingly popular in developing countries due to their efficiency and environmental concerns. However, fossil fuel vehicles are still dominant in Indonesia due to their more affordable prices. The Indonesian government supports the transition to electric vehicles with various incentives and infrastructure development. CAN-Bus technology is used for communication between vehicle components, enabling efficient monitoring and control. However, communication challenges between vehicles and charging stations still exist. Therefore, this project aims to develop a

Power Line Communication (PLC) based communication system that utilizes the existing electricity network. The research method includes designing and testing a prototype EVPLC system to improve the efficiency and adoption of electric vehicles in Indonesia.

1.1 Background

Over the years, electric vehicles have become a common part of daily human life, especially in advanced countries. This event is driven by the efficiency and technological advancement provided by electric vehicles and the growing awareness towards a healthier way of living for the environment. Here in Indonesia, fossil-fueled vehicles are still society's favorite since most electric vehicles are still out of reach for most Indonesian citizens because of the soaring prices, and the low will to try new technological advances since society can already rely on fossil-fueled vehicles for decades. Yet, there is growth in Indonesia, in both government and society, in the transition process from fossil-fueled vehicles to electric vehicles. Some societies are already willing to change their vehicles to electric vehicles, both cars and scooters, and the government creates regulations that support the usage of electric vehicles such as lower vehicle taxes, free from even-odd regulations, and even infrastructure that supports the usage of electric vehicles such as the rapid growth of charging stations for electric vehicles [1]. Those previous actions created a thriving momentum for using electric vehicles in Indonesia.

In electric vehicles, there is an applied technology called the CAN (Central Area Network) Bus. CAN-Bus is a type of automotive bus. An automotive bus is a communications network that interconnects underlying automotive devices or automotive instruments in the in-vehicle network. CAN bus was originally designed by Bosch in 1989 for automotive monitoring and controls and was used in communications between the measurement and execution components of a car [2]. It can be

summarized that CAN-Bus is a protocol that has a direct relationship with the components inside the vehicle, which means that through CAN-Bus, it is possible to observe the current condition of the components inside the vehicle. Based on the research document titled "Development of a CAN-BUS Based Electric Car Control System" by the National Technology Institute, there are several components in electric vehicles that can be integrated with CAN-BUS [3]. These are vehicle control systems, energy storage systems, motor and power inverters, charging station infrastructure, vehicle support systems, and transmission. In this research, the researchers are focused on the energy storage system in electrical vehicles. Since the wiring mechanism is already available through the implementation of CAN-Bus, the technology can become a part of the Smart Grid implementation in the electric vehicle industry through the presence of a gateway. This can be implemented through the presence of PLC (Power Line Communication). Power Line Communication (PLC) presents some natural advantages that make it appropriate for this kind of application, such as the advantage of using the already deployed electrical grid as the communication medium [4].

Unfortunately, EV-PLC technology is still rarely used in the market nowadays, even in advanced countries. By not using EV-PLC technology, the user needs to go to the workshop only to analyze the complete condition of the EV since not every electric vehicle is built with an embedded network that can analyze the state of the vehicle, especially in electric motorbikes that recently became commonly used by Indonesian drivers. Different types of electric vehicles can use various current and voltage levels, affecting the battery health over long runs. Combining both technologies can bring abundant benefits to both the user of the electric vehicle and the industry because it would enable them to analyze every component that is connected and reprogram it to the user's satisfaction. Following further developments, it can self-diagnose the components in the electric vehicle. In the previous year, a group of students from Telkom University worked on research entitled "Designing Public Electric Vehicle Charging Stations in the Telkom University Environment" [5]. From that research, the students created a charging station in which the communication system. However, the electric path can be detected by the electric vehicle used. However, communication still works based on the principle of basic impedance. This research aims to form an electronic device that can be implemented in several types of charging stations and functions as a gateway technology between electronic vehicles and

charging stations. Of course, by considering the IEC (International Electrotechnical Commission) standardization which is widely used for electric vehicles in Indonesia. Recently, there have been several companies that have created this kind of gateway technology. These companies are Continental Engineering Services (CES) headquartered in Frankfurt, Germany; Renault from France; Xingtera and Star Charge from China. As previously mentioned, the purpose of this research is to create an EV-PLC (Electrical Vehicle Power Line Communication) which functions as a communication interface between the electric vehicle used and the charging station. The purpose of this activity is to initiate research initiatives and the manufacture of EV-PLC technology in Indonesia considering the increasing interest in electric vehicles in Indonesia.

1.2 Requirement to be Fulfilled

The requirements that must be met based on the existing background are as follows:

1. The instrument can convert the given PLC signal into data that can be recognized by the EVCAN Simulator.
2. The instrument can communicate data in two directions between the Electric Vehicle Charging Station (EVCS) and the EVCAN Simulator.

1.3 Purpose

The goal of this project is to develop an efficient and reliable communication system for electric vehicles in Indonesia. By utilizing Power Line Communication (PLC) technology, this system aims to integrate communication between electric vehicles and charging stations. This is expected to support the government's efforts in encouraging the adoption of electric vehicles and achieving lower net emission targets.

2 Supporting Information and System Design

CAN-Bus technology is a communication system that allows efficient data exchange between vehicle components. This is essential for real-time monitoring and control in electric vehicles. Power Line Communication (PLC) utilizes the existing electrical network for data communication, reducing the need for additional cables and increasing system flexibility. This study uses a design and test approach. A prototype EVPLC system was developed to integrate CAN-Bus and PLC technologies. Testing was performed to ensure the reliability and efficiency of communication. The system is designed with level 1 and 2 block diagrams

that describe the relationship between components. The system includes a PLC and CAN-Bus communication module connected through a microcontroller.

2.1 Supporting Information

Before CAN was introduced, every electronic device was connected to every other device using a few cables to enable communication. However, as the functionality in the car system increased, it became difficult to maintain it due to the tedious wiring system. With the help of the CAN bus system, which allows ECUs to communicate with each other without much hassle by simply connecting each ECU to a common serial bus [6]. The CAN bus protocol was initially designed as an alternative to the field bus technology in cars that would increase functionality [7]. The first car to ever feature this technology was the BMW 850 Coupe that hit the market in 1986. The car was able to reduce the wiring in the vehicle by 2 km, which in turn significantly reduced its weight by more than 50 kg. Not to mention, the vehicle systems and sensors were able to communicate with each other at speeds of up to 25kbps - 1Mbps [7].

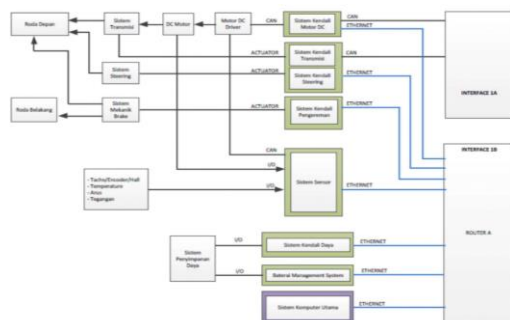

Figure 2.1 Electric Vehicle Block Diagram for CAN

(Figure 2.1) shows several components of electric vehicles that can be integrated with CAN-BUS. These components are vehicle control systems, energy storage systems, motors and power inverters, charging station infrastructure, vehicle support systems, and transmissions. In this study, researchers focused on the energy storage system whose data will be received by EVPLC. The application of Electric Vehicle-Power Line Communication (EVPLC) technology in Indonesia has enormous potential because it can be an important bridge between existing CAN-Bus technology in electric vehicles and charging infrastructure. This advancement not only facilitates communication between electric vehicles and charging stations, but also opens up opportunities for real-time analysis, reprogramming, and self-diagnosis of vehicle components, thereby improving user experience and reducing maintenance costs.

2.2 Product Requirement and Specification

The requirements and specifications that needs to be fulfilled during this research are summarize into the table below.

Table 2. 1 Research Requirement and Specification

No	Requirement	Spesification
1	The instrument can convert the given PLC signals into recognizable data for the EVCAN Simulator.	The given PLC signals can be recognized with CAN Bus Protocol as an embodiment of the EVCAN Simulator system.
2	The instrument can communicate data bidirectionally between Electric Vehicle Charging Stations (EVCS) with an EVCAN Simulator.	The instrument is capable of transferring and receiving data for the EVCS and EVCAN Simulator.

2.3 Verification

Table 2. 2 First Verification from Specification

Specification	The given PLC signals can be recognized with CAN Bus Protocol as an embodiment of the Electric Vehicle system.
Measurement Method	User Observation of the HMI of the EVCAN Simulator
Testing Procedure	The test will use the HMI from EVCAN Simulator, the user observes the data from the HMI EVCAN Simulator whether the data from EVCS is sent and received by EVCAN Simulator, it means that EVCAN Simulator already recognizes the EVPLC communication protocol.

Table 2. 3 Second Verification from Specification

Specification	The instrument is capable of transferring and receiving data for the EVCS and Electric Vehicle or EVCAN Simulator.
Measurement Method	User Observation of the HMI in the EVCS and EVCAN Simulator.

Testing Procedure	The test will use the HMI from EVCS and EVCAN Simulator, the user observes the data from the EVCS HMI whether it is in accordance with the data sent from the EVCAN Simulator and observes the HMI from the EVCAN Simulator with the same data as the data sent from EVCS.
-------------------	--

Voltage Sensor	ZMPT101B
Power Supply	Powerbank

2.4 Solution Concept

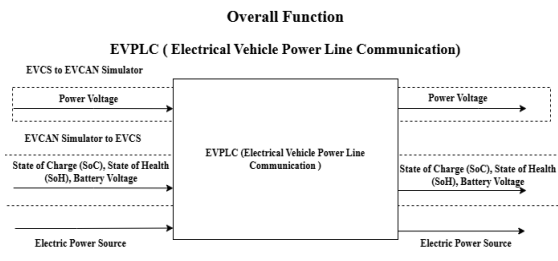

Figure 2.2 Overall Function of EVPLC System

Based on the function block diagram above (Figure 2.4), Overall Function of Electric Vehicle Powerline Communication, the Communication System in the system can be bidirectional therefore it has 2 inputs, the first input is Data from EVCS in the form of Power Voltage Data, and will produce output Power Voltage data that has been demodulated and will be displayed on the Control Pilot EV or HMI of EVCAN Simulator, then the second input is from the EV in the form of State of Charge (SoC), State of Health (SoH) and Battery Voltage Data, and will produce data output State of Charge (SoC), State of Health (SoH) and Battery Voltage Data which will be displayed on the HMI from EVCS.

2.5 Selected Component

Based on the previous information about research requirements, specifications, and proposed solutions, the following is a list of selected components required to build a functional EVPLC module. These components are detailed in the table below.

Table 2. 4 Selected Component

Selected Component	
Microcontroller	Arduino Nano
Case Design	Acrylic
HMI	Nextion (NX4024K032 011)
CAN Module	MCP2515
PLC Module	KQ330

2.6 System Design

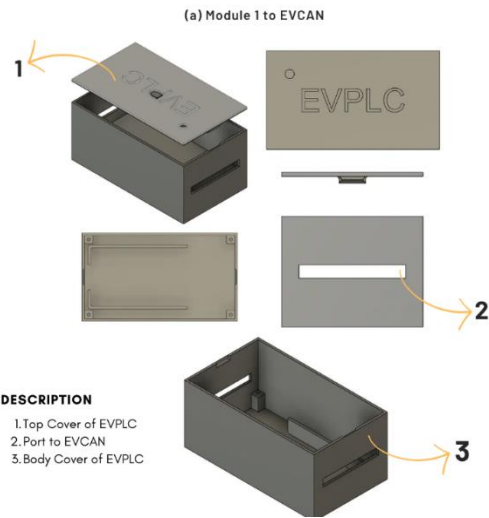

Figure 2.3 Module 1 of EVPLC Design

The (Figure 2.5) above illustrates that in the EVPLC system design, Power Line Communication (PLC) technology enables bidirectional communication between the Electric Vehicle Charging Station (EVCS) and the Electric Vehicle Controller Area Network (EVCAN) Simulator. This allows data to be sent and received in both directions between the EVCS and the EVCAN Simulator. In the design of Module 1 of the EVPLC system, PLC technology is a key component, which is connected via a 220V power line, and acts as a bridge for CAN communication to collect data from the EVCS and the EVCAN Simulator. With this arrangement, the PLC module can send and receive data simultaneously, based on the information collected from the CAN communication between the EVCS and the EVCAN Simulator. The integration of code in the system facilitates data transfer from the EVCS to the EVCAN Simulator and data reception from the EVCAN Simulator to the EVCS, ensuring efficient data transmission over the power line.

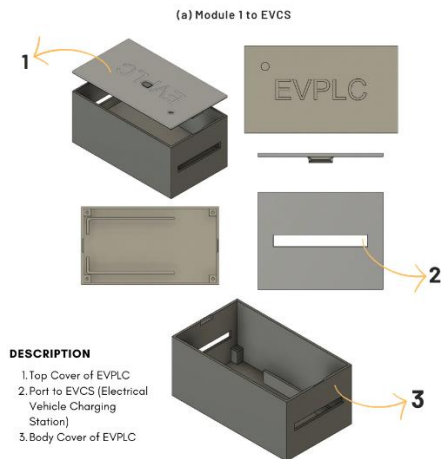

Figure 2.4 Module 2 of EVPLC Design

Similar to the role of Module 1, (Figure 2.6) illustrates that Module 2 in the EVPLC system design features Power Line Communication (PLC) technology capable of bidirectional communication between the EVCAN Simulator and EVCS. This allows data to be sent and received from the EVCAN Simulator to the EVCS, and vice versa. In the Module 2 design for the EVPLC (Electric Vehicle Power Line Communication) system, PLC technology serves as the main component, connected via a 220V power line, which acts as a CAN interface to collect data from the EVCAN Simulator and EVCS. With this arrangement, the PLC module can send and receive data simultaneously, managing the data captured via CAN communication from the EVCAN Simulator and EVCS. The code integration in this system ensures that data can be sent from the EVCAN Simulator to the EVCS and received from the EVCS, allowing the EVPLC to send available or required data between the systems. The main difference from Module 1 lies in the specific code and data flow between the systems. This integration facilitates efficient data transmission over the power line[8].

3 Discussion

In this study, our focus is to develop an EVPLC system, which includes two subsystems: EVPLC Master and EVPLC Slave. We also work closely with another team to integrate their EVCAN Simulator into one of our subsystems. In addition, we have an additional EVCS Simulator subsystem that supports the overall functionality of our system. The EVPLC module is built on three essential components, namely a communication module (KQ330), an Arduino Nano microcontroller, and a CAN-BUS gateway (MCP2515). The goal is to create a portable module that can be seamlessly connected to an existing CAN-BUS network without the need for additional circuitry, enabling

communication over AC power via the KQ330. The MCP2515 is chosen to handle the CAN-BUS communication.

3.1 Main System

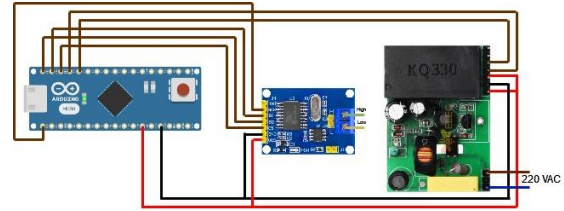

Figure 3.1 Wiring Diagram of EVPLC Module

As shown in (Figure 3.1) and based on the selected components, our main system EVPLC System Module is built on three core components: Arduino Nano, MCP2515 (CAN Module), and KQ330 (AC Communication Module) for the Master and Slave is the same but the different only in the code.

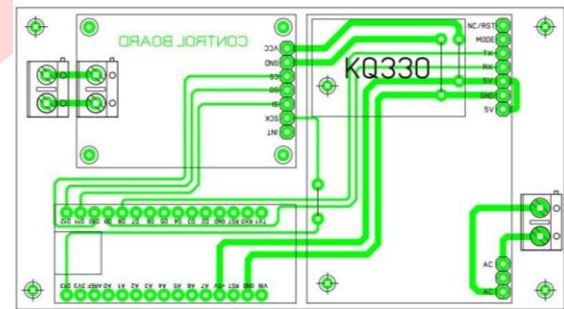

Figure 3.2 PCB Design for EVPLC Module

Once the final module circuit is complete, the next step in completing the module is to design the PCB based on the existing circuit. Once the PCB design is complete, the PCB will be printed, and the module components will be integrated into the board. The PCB will be stand-alone, powered by an embedded power bank that will be placed inside the EVPLC module casing.

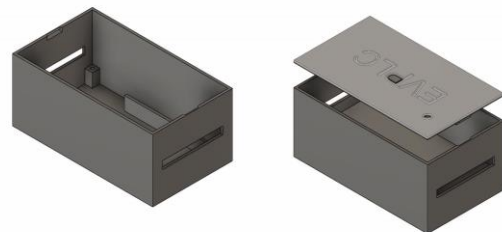

Figure 3.3 3D Design of EVPLC Module Casing

3.2 Sub System

The system consists of two subsystems. The first is the EVCAN Simulator, which was developed in collaboration with other teams and serves as a simulated electric vehicle. The second subsystem,

which we are currently developing, is the EVCS Simulator. The goal is to test whether this system can successfully transmit battery-related data from the EVCAN Simulator to the EVCS Simulator, as well as transmit power voltage data from the EVCS to the EVCAN Simulator. Although specific data variables can be adjusted as needed, this study focuses on using power voltage as the primary data for transmission.

3.2.1 EVCAN Simulator



Figure 3.4 EVCAN Simulator

In this research, we collaborated with another team that created the EVCAN simulator to integrate this EVPLC communication system, as seen in (Figure 3.4) The EVCAN simulator is an electric car simulation that has the most important component to communicate the entire network in an electric car, namely CAN or CAN (Controller Area Network) which is the central hub for collecting data from sensors connected to it in Electric Vehicles (EV). Several CAN systems in the vehicle collect information, which is then aggregated into a main CAN module. This main CAN, which is usually connected to a Human-Machine Interface (HMI), displays the collected information to the user, especially focusing on battery-related information such as State of Charge (SoC), State of Health (SoH), and Battery Voltage.

3.2.2 EVCS Simulator

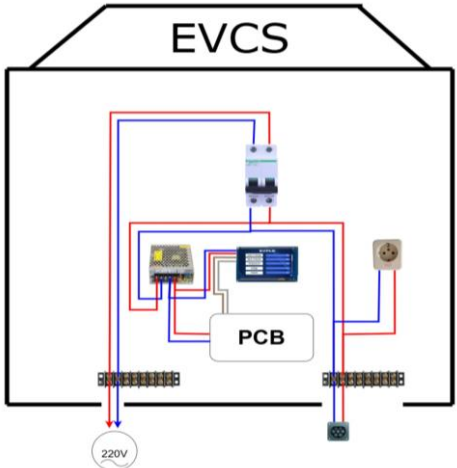

Figure 3.5 Wiring Diagram of EVCS Simulator

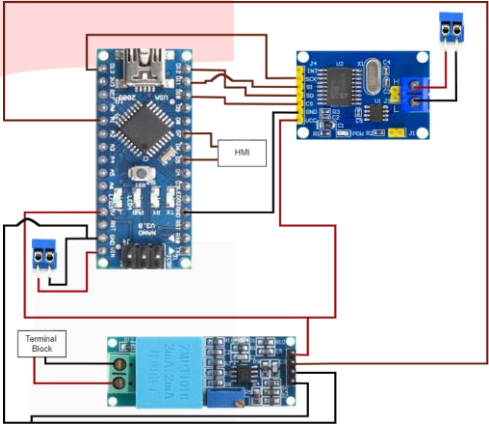

Figure 3.6 Wiring Diagram PCB in EVCS Simulator



Figure 3.7 EVCS Simulator

In this research we also create EVCS Simulator to help integrate EVPLC and in (Figure 3.7) above This is EVCS simulator, not capable of charging real electric vehicles or fully functional as real EVCS. The purpose of this simulation is to show that EV-PLC system works correctly and meets the objectives for potential EVCS implementation in real world, with necessary modifications. In this simulation, EVCS collects data through integrated

sensors and sends the results to EV-CAN Simulator through EV-PLC module.

3.3 System Testing

The next stage is that the researchers tested the EVPLC module with EVCS Simulation and EVCAN Simulation to test the success of the EVPLC module. From the test, the results were very satisfactory and met all the requirements of the module. This also proves that integrating the EVPLC module into the actual EVCS and electric vehicles is possible and beneficial. The final test documentation is as follows.



Figure 3.8 HMI of EVCAN Simulator



Figure 3.9 HMI of EVCS Simulator

From the two (Figure 3.8 and Figure 3.9) above, we can observe the results of the system testing. The HMI on the EVCS Simulator displays battery-related information sent from the EVCAN Simulator, while the HMI on the EVCAN Simulator displays power voltage data sent from the EVCS Simulator.

4 Conclusion

The EVPLC (Electric Vehicle Power Line Communication) system is designed to advance the technology supporting electric vehicles, especially focusing on the crucial charging process. Considering that electric vehicles use CAN (Controller Area Network) to integrate all sensors and data, the research of the EVPLC module aims to bridge the communication between electric vehicles and charging stations. Tests with the EVCAN Simulator and EVCS have shown that AC communication can be effectively implemented with electric vehicles. With further development, the EVPLC module can be integrated with EVCS and

actual electric vehicles, paving the way for better systems and real-time monitoring of electric vehicles.

5 Bibliography

- [1] Biro Komunikasi dan Informasi Publik, "Pemerintah Terus Dorong Penggunaan Mobil Listrik," Kementerian Perhubungan Republik Indonesia.
- [2] J. N. Luo, C. M. Wu, and M. H. Yang, "A can-bus lightweight authentication scheme," *Sensors*, vol. 21, no. 21, Nov. 2021, doi: 10.3390/s21217069.
- [3] T. K. S. T. M.T, Dr. Waluyo MT., and S. S. T. M.T., "Pengembangan Sistem Kontrol Mobil Listrik Berbasis CAN-Bus," *IEEE*, 2016.
- [4] G. López *et al.*, "The role of power line communications in the smart grid revisited: Applications, challenges, and research initiatives," *IEEE Access*, vol. 7, pp. 117346–117368, 2019, doi: 10.1109/ACCESS.2019.2928391.
- [5] P. Stasiun and P. Kendaraan, "BUKU TUGAS AKHIR CAPSTONE DESIGN."
- [6] Akhila Nagaruru, "Understanding Controlled Area Network (CAN) for Automobile Industry needs," PATHPARTNER. Accessed: Oct. 20, 2023. [Online]. Available: <https://www.pathpartnertech.com/understanding-controlled-area-network-can-for-automobile-industry-needs/>
- [7] "CANBus: The Central Networking System Of Vehicles," premio. Accessed: Oct. 20, 2023. [Online]. Available: <https://premioinc.com/blogs/blog/can-bus-the-central-networking-system-of-vehicles>
- [8] A. T. R. G. D. B. S. + A. R. A. Daru, "CAPSTONE DESIGN FINAL PROJECT BOOK Communication System Between Electric Vehicles and Electric Vehicles Charging Stations Based on AC Powerline Carrier Diajukan untuk memenuhi syarat kelulusan program sarjana di Prodi S1 Teknik Elektro," 2024.